



Vision Range

VSXUS OWNERS MANUAL



WARNING: Improper installation, adjustment, alteration, service or maintenance can cause property damage, injury or death. Read the installation, operating and maintenance instructions thoroughly before installing or servicing this equipment.



Introduction.

Welcome to the new range of high efficiency AmbiRad VSXUS infra-red heaters. Local regulations may vary and it is the installer's responsibility to ensure that such regulations are satisfied.

All installation, assembly, commissioning and service procedures must be carried out by suitable qualified competent persons and conform with local building codes, or in the absence of local codes, with the National Fuel Gas Code ANSI Z223.1/NFPA 54.

When assembling, installing, commissioning and servicing is undertaken on radiant tube heaters specified in these instructions, due care

and attention is required to ensure that working at height regulations are adhered to at the mounting heights specified.



PLEASE READ this document prior to installation to familiarize yourself with the components and tools you require at the various stages of assembly.

All Dimensions shown are in inches unless otherwise stated.

The manufacturer reserves the right to alter specifications without prior notice.

Document Index.

1 Installation Requirements

- 1.1 Health & Safety
- 1.2 Packing and Shipping Information
- 1.3 Heater Suspension
- 1.4 Wall Mounting
- 1.5 Clearance to Combustibles
- 1.6 Gas Connection & Supply Details
- 1.7 Electrical Connections
- 1.8 Ventilation Requirements
 - 1.8.1 Unvented Units
 - 1.8.2 Vertical Venting
 - 1.8.3 Horizontal Venting
 - 1.8.4 Fresh Air Intake
- 1.9 Vent & Combustion Air Inlet
- 1.10 Technical Details

2 Assembly Instructions

- 2.1 Tools Required
- 2.2 Identification Check List
- 2.3 Prior to Assembly
- 2.4 Assembly Instructions
 - 2.4.1 Turbulators
 - 2.4.2 Brackets, U bolts and U bend
 - 2.4.3 Reflectors
 - 2.4.4 End Caps
 - 2.4.5 Canopies
 - 2.4.6 Canopy End Caps

2.4.7 General

2.4.8 Detailed Assembly Drawings

3 Start Up Instructions

- 3.1 Tools Required
- 3.2 Start up procedure

4 Servicing Instructions

- 4.1 Tools Required
- 4.2 Burner Description
- 4.3 Burner Removal
- 4.4 Burner Gas Injector Servicing
- 4.5 Burner Head and Electrode Servicing
- 4.6 Combustion Fan Assembly
- 4.7 Radiant Tube Servicing
- 4.8 Heat Exchanger Servicing
- 4.9 Reflector Servicing
- 4.10 Sweeping of Vent
- 4.11 Re-commissioning after Service

5 Spare Parts

6 Troubleshooting Guide

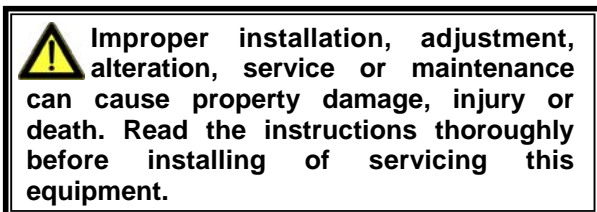
7 Replacing Parts

- 7.1 Burner Controller Replacement
- 7.2 Air Pressure Switch Replacement
- 7.3 Gas Valve Replacement

8 User and Operating Instructions

- 8.1 To Start Heater

1. Installation Requirements.



1.1 Health and Safety

A. Heater is intended for heating

non-residential indoor spaces and should only be installed where flammable gases or vapors are not generally present.

- B. Heaters may be suspended either horizontal or at an angle, or may be wall mounted. See section A3 for clearance dimensions.
- C. The installation must conform with local building codes or, in the absence of local codes, with the *National Fuel Gas Code, ANSI Z223.1/NFPA 54*.

1. Installation Requirements.

- D. The unit shall be electrically grounded in accordance with National Electric Code ANSJJNFPA 70.
- E. The heater may be installed in aircraft hangars installed in accordance with the Standard for *Aircraft Hangars, ANSI/NFPA 409* and in automotive garages when installed in accordance with the Standard for *Parking Structures, ANSI/NFPA 88A*, or the Standard for *Repair Garages, ANSI/NFPA 88B*, and are so marked.
Ensure that minimum clearances will be maintained to vehicles parked below the heater.

1.2 Packing and Shipping Information

See section 2 for assembly drawings. Material list with part numbers and descriptions for each part will accompany each shipment.

Heaters include:	Options:
Burner/Control	
Heat Exchanger	
Radiant Tubes	
Reflectors/Canopies	
Brackets	Ball Valve
Fan	Vent Hoods
U-Bend	Hanging Assembly
Flex Gas Connector*	(Chain etc)
Tube Couplings	

* Connector must be certified for use on a radiant tube type infrared heater and must comply with Standard for Connectors for Gas Appliances, ANSI Z21.24/CSA 6.10 for the United States.
For heaters up to 150,000Btu/h, ½" ID x 24" long

Shipping packages for individual projects will be boxed and crated as outlined in the specific bill of lading.

Table 1. Recommended Mounting Heights

Model	Mounting Height (ft)			
	Standard		Inclined	
	min	recommended	min	recommended
90	14	16	12	13
140	16	18	14	15

1.3 Heater Suspension

Attachment to the heater support lugs should be made by a 'speed link', D shackle or in the case of drop rods, a closed formed hook. The hanging attachments to overhead steelwork etc. must be purpose made to good sound engineering practice or of a proprietary type fixing. They must be adequately fixed and designed to carry the whole weight of the heater. In the event of suitable roof steelwork being unavailable, additional steelwork should be fitted to enable vertical hangers to be used for suspending the heaters.

These methods are illustrated in Figure 1. If there are any doubts as to the strength or suitability of roof steelwork to which heaters are to be suspended, please refer to a Consultant, Architect or owner of the building.

It is recommended that the heater is raised to its final position once the assembly of the tube/bracket/reflector has been completed.

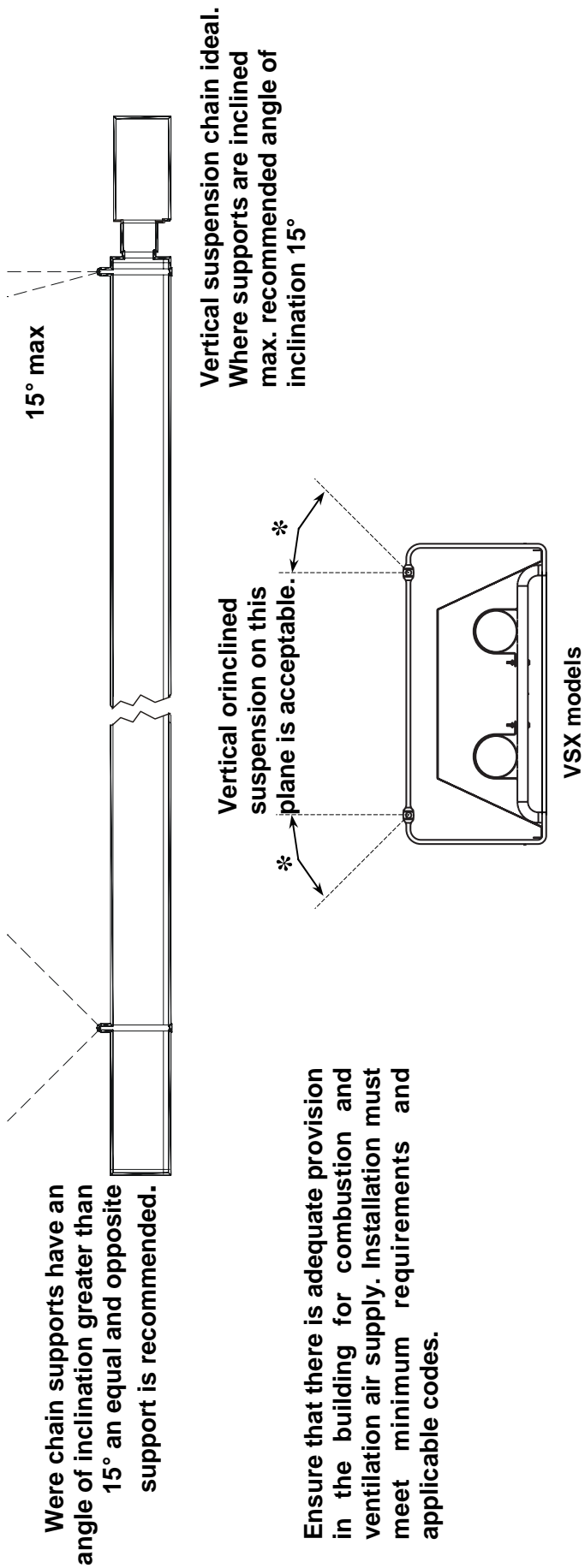
The suggested mounting heights for AmbiRad heaters are given in table 1 below.

1.4 Wall Mounting

These radiant tube heaters can be wall mounted using the appropriate bracket.

When using the wall mounting brackets the heater must be inclined at an angle between 35° and 55°.

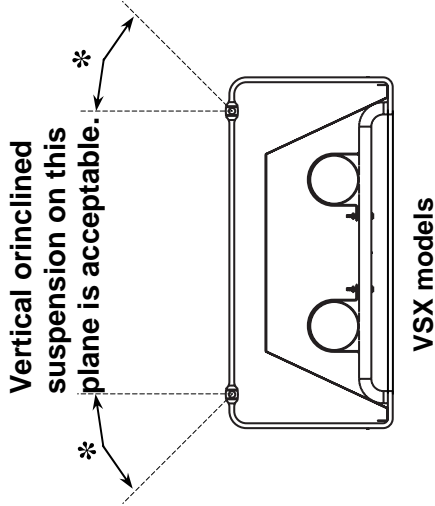
Figure 1. Recommended Methods of Heater Suspension.



Were chain supports have an angle of inclination greater than 15° an equal and opposite support is recommended.

15° max

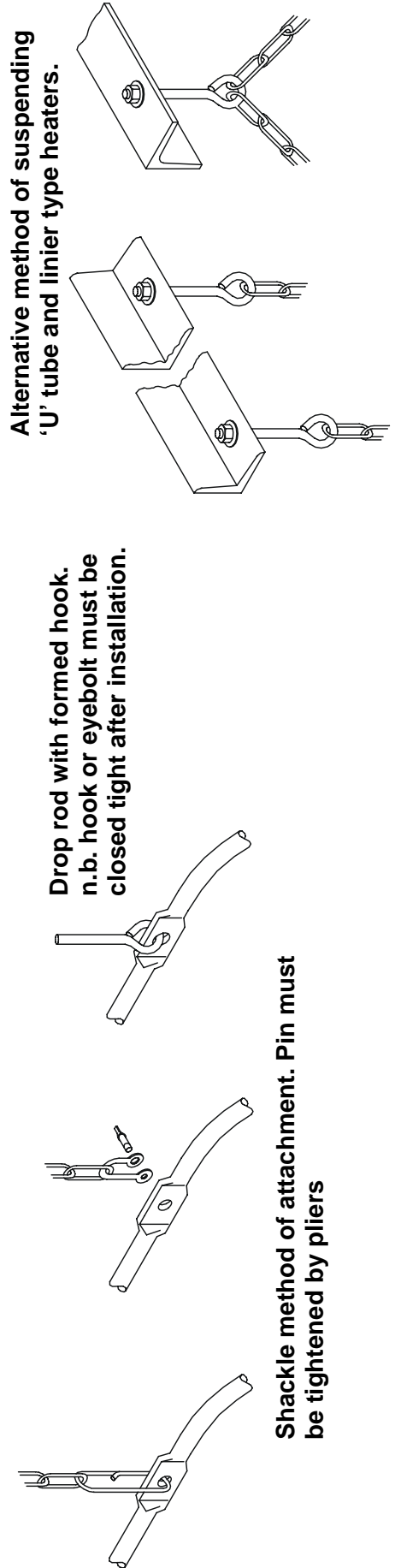
Vertical suspension chain ideal. Where supports are inclined max. recommended angle of inclination 15°



VSX models

Ensure that there is adequate provision in the building for combustion and ventilation air supply. Installation must meet minimum requirements and applicable codes.

IMPORTANT: THE HEATER SHOULD SLOPE DOWNWARDS TOWARDS THE RETURN BEND BY APPROX. 10mm FOR BOTH HORIZONTAL AND WALL MOUNTED INSTALLATIONS.




Alternative method of suspending 'U' tube and liner type heaters.

Drop rod with formed hook. n.b. hook or eyebolt must be closed tight after installation.

Shackle method of attachment. Pin must be tightened by pliers

1.5 Clearance to Combustibles.

 The minimum clearances to combustible materials are given in the tables below. These minimum distances **MUST** be adhered to at all times.

IMPORTANT:

The stated clearance to combustibles represents a surface temperature of 90°F (32°C) above room temperature. Building material with a low heat tolerance may be subject to degradation at lower temperatures.

It is the installer's responsibility to assure that adjacent material are not subject to degradation.

Figure 2 Diagram illustrating the clearance to combustibles

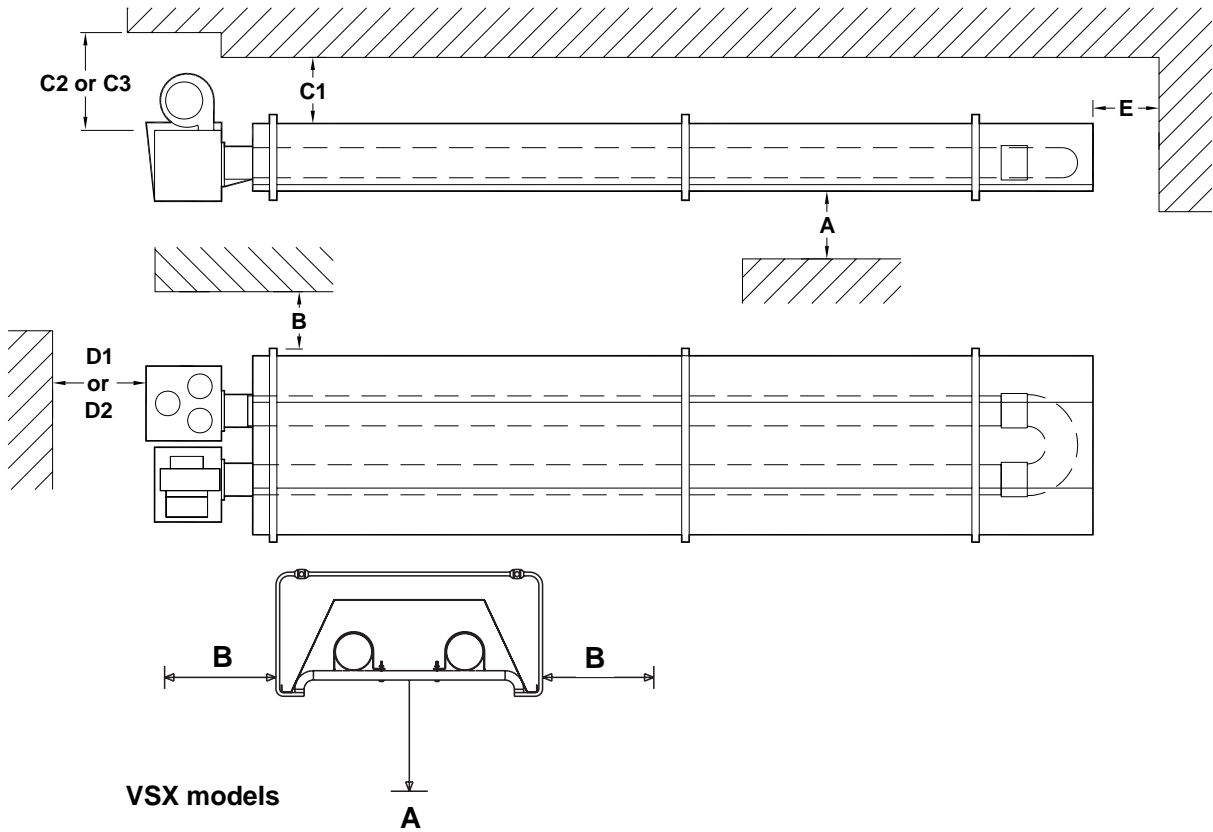



Table 2. Clearances to combustibles VSXUS

		VSXUS90 (ins)	VSXUS140 (ins)
Below Tubes	A	82	90
To the Sides	B	35	35
Above Reflector	C1	4	4
Above Burner / Heater Outlet Vented	C2	20	20
Above Burner / Heater Outlet Unvented	C3	24	24
Behind Burner	D1	32	42
Behind Burner with Vent connected	D2	24	24
End Wall	F	21	21

 **WARNING:**
Minimum clearance from the heater must be maintained from vehicles parked below heater. In all situations, clearances to combustibles must be maintained. Signs should be posted in storage areas to specify maximum stacking height to maintain required clearance to combustibles. Refer to mounting clearance tables.

1.6 Gas Connection and Supply


WARNING: Before installation, check that the local distribution conditions, nature of gas and pressure, and adjustment of the appliance are compatible.

The gas connection on the heater is 1/2" N.P.T external thread.

Injector sizes and manifold pressure for the burners are shown in the table 3. The gas supply piping and connections must be installed so that the minimum pressure stated is achieved.

A gas shut off valve and union should be fitted in the gas supply line close to the heater and a 1/8" N.P.T plugged tapping, accessible for test gauge connection, provided immediately upstream of the appliance gas inlet.

It is essential to provide some flexibility in the final gas connection preferably by use of an approved flexible gas connector or stainless steel expansion loop.

 Take care when making a gas connection to the heater not to apply excessive turning force to the internal controls.

Depending on the specific installation, the flexible gas hose may be routed to the gas cock at any of the following angles in relation to the burner:

Care must be taken to observe the minimum pipe bend diameter (minimum 10", maximum 14") & pipe expansion distance (minimum 1 1/8", maximum 3 3/4").


 The correct installation as shown will allow for approx 4" of movement due to expansion.

Figure 3. Correct orientation of Ball Valve

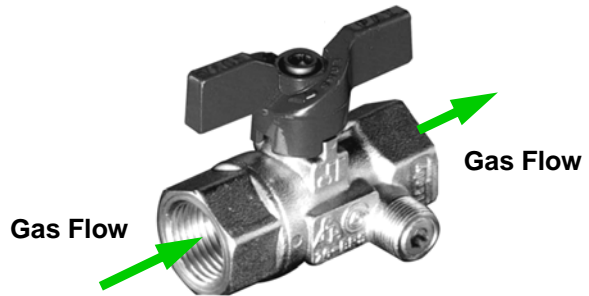
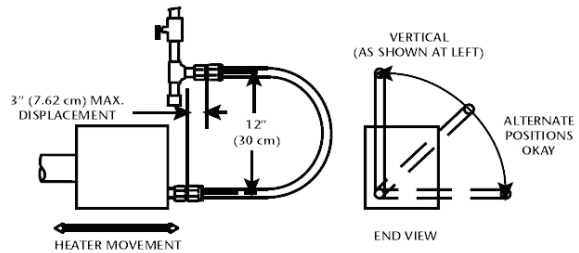
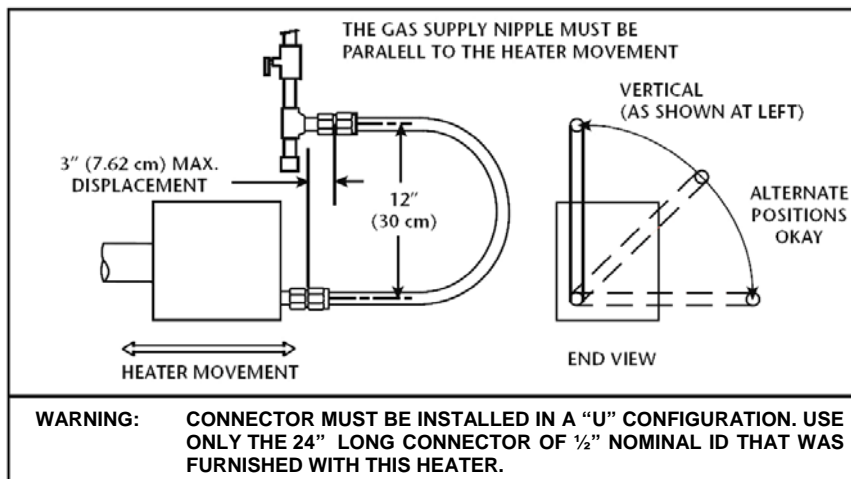
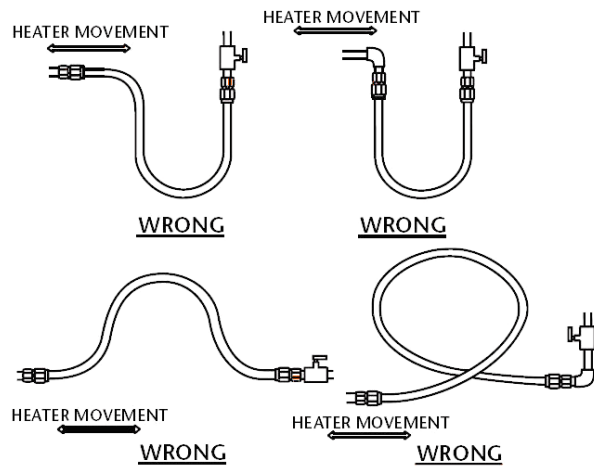


Figure 4. Correct Installation of Flexible Gas Connection

CORRECT POSITIONS



INCORRECT POSITIONS



⚠ WARNING: FIRE OR EXPLOSION HAZARD - Expansion of the radiant pipe occurs with each firing cycle causing the burner to move with respect to the gas line. This can result in a gas leak producing an unsafe condition. It is therefore essential to provide some flexibility in the final gas line connection by use of an approved armoured flexible connector or stainless steel expansion loop as shown in the drawings.

Table 3 Gas Supply Pressures

Gas Type	Natural Gas
Required Gas Pressure (in W.C)	7.0
Maximum Supply Pressure (in W.C)	14.0
Gas Supply	Connection ½" N.P.T internal thread

1.7 Electrical Connections

⚠ WARNING: Before making electrical connections, switch OFF the main electrical disconnect. There may be more than one disconnect switch. Lock out and tag switch with a suitable warning label. Electrical shock can cause personal injury or death.

This appliance must be electrically grounded

Supply 120V 60Hz single phase.
 Standard heater 0.16HP.
 Current rating 1.2 amp max (inductive).
 Fuse: external 3 amp.

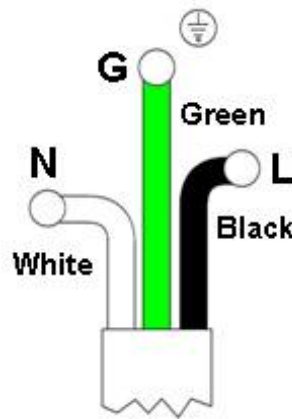
Important: All electrical work should be done by a qualified electrician in strict accordance with the National Electrical Code ANSI/NFPA 70.

The electrical supply to the heater is by three wires: live, neutral and ground connections.

Install in accordance with all state & local codes.

It is recommended that the electrical circuit controlling the heater or group of heaters include thermostats and if required manual control switches. All such controls and switch gear must be rated to handle the total inductive load of the circuit they control. For large installations the use of relays or contactors should be considered.

Control panels are available from the manufacturer incorporating multiple Black Bulb Thermostats controlling up to 10 heaters per thermostat for zone control of the heated area.



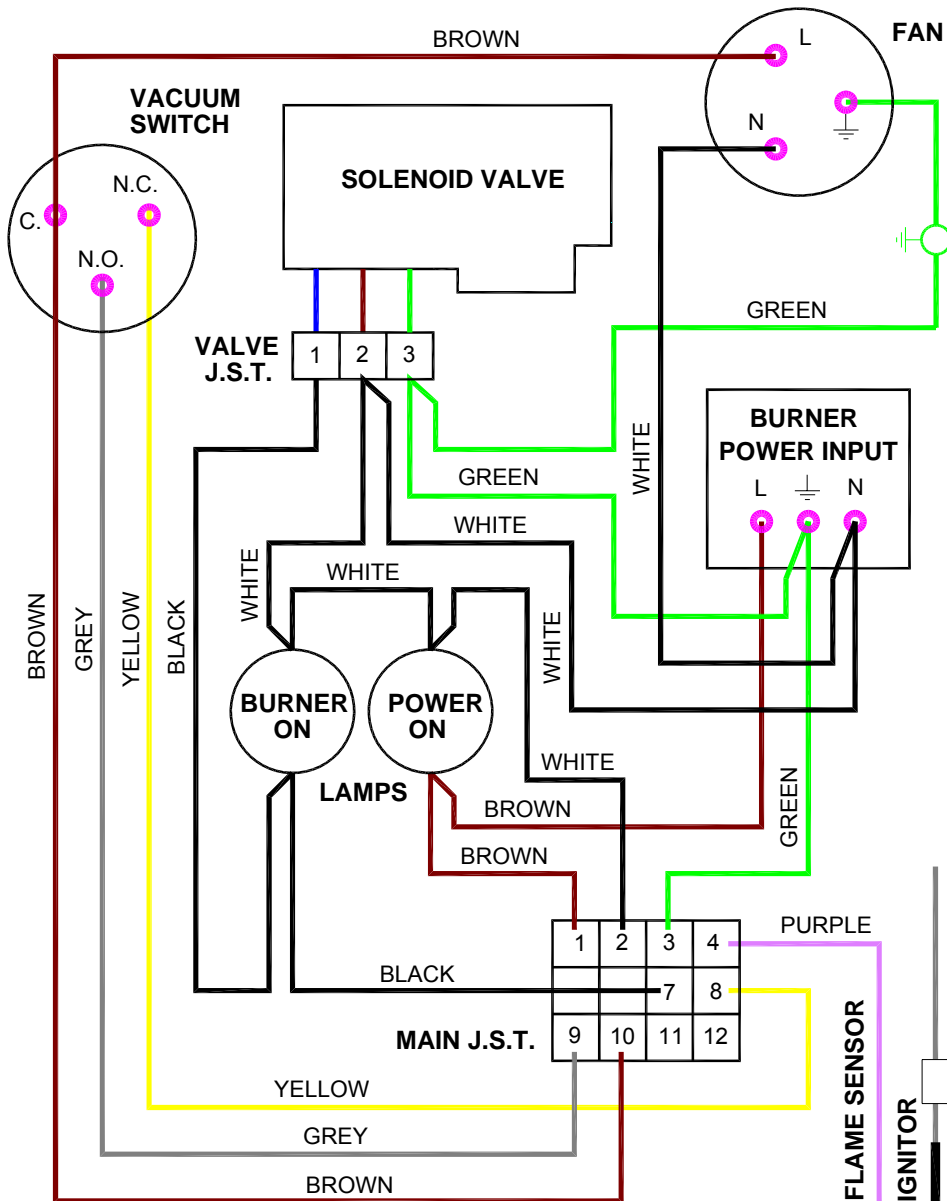
(Control Panels are not A.G.A/CSA design certified)

Where alternative manufactures' controls are used, please refer to their instructions for their siting and installation details.

Figure 5. Typical VSXUS Wiring Connections

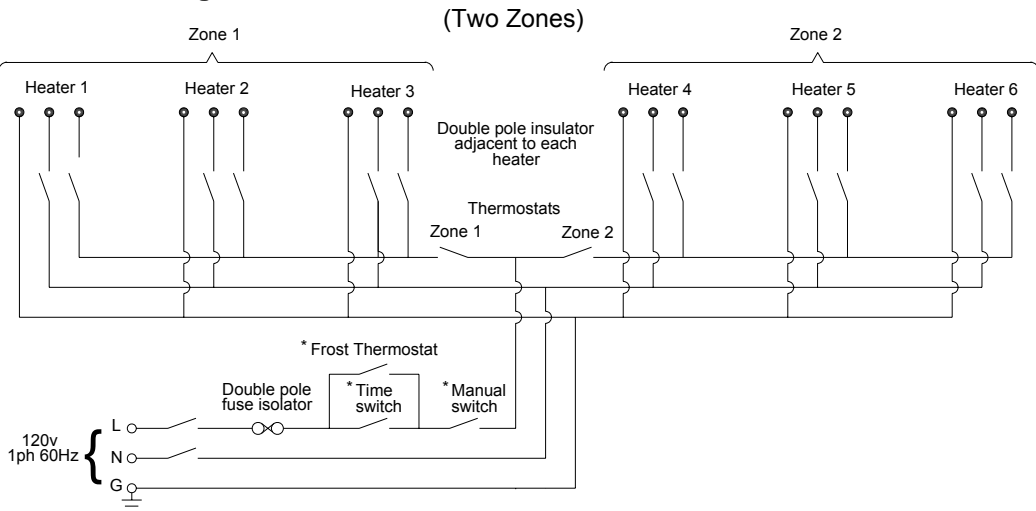


Figure 6. Internal Burner Wiring Diagram.



! If any of the original wire as supplied with the appliance must be replaced, it must be replaced with wiring material having a temperature rating of at least 220°F/105°C

Figure 7. External Wiring Schematic.



1.8 Vent Requirements and Details

1.8.1 Unvented units

Heaters maybe installed without a vent providing the governing building codes are met and consideration is properly given to possibilities of condensation on cold surfaces.

Installation shall meet the following requirements when unvented:

- Internal volume of the heated room must be greater than 214cu.ft. per 100 BTU/HR of heaters installed.

OR

- Natural or mechanical means shall be provided to supply and exhaust at least 4 CFM per 1000 BTU per hour input of installed heaters.
- Combustion gasses shall not impinge on combustible materials with a temperature in excess of 150°F.

1.8.2 Vertical venting

The heater can be installed with a vertical vent.

All vent piping should be adequately supported from the building structure and terminated with an approved terminal. All connections should be properly sealed. refer fig 8a & 8c

1.8.3 Horizontal venting

Individual units can be vented horizontally through side walls. Recommended terminals are AmbiRad V0700 for 4" and V0800 for 6".

Distances from adjacent public walkways, adjacent buildings, openable windows and building openings, consistent with the *National Fuel Gas Code, ANSI Z223.1/NFPA 54*.

Maximum length of vent is 25ft with 2 - 90° long radius elbows.

Runs of 12ft or shorter can use 4" dia vent. Runs over 12ft should use 6" vent pipe.

Any portion of vent that passes through a combustible wall must be insulated, or use an approved insulating thimble.

Standard vent terminals must extend at least 6" from the wall and at least 24" from any combustible overhang. Protect the building material from degradation by the vent gasses.

Vent joints should be sealed and secured using at least 3 sheet metal screws. Should condensation occur the vent should be shortened or insulated.

The terminal should be at least 3ft away from any air intake to the building

If the heater is equipped with ducted combustion air, the vent terminal must be at least 3ft away from the air inlet and located higher than the inlet.

The vent terminal must be protected from blockage by snow.

1.8.4 Fresh Air Intake

Whenever the heater is installed in locations where airbourne dust or other pollutants are present, a fresh air supply should be ducted to the burner.

A fresh air duct of 4" dia. Should be installed from the fresh air to the air intake connection on the fan housing.

A flexible jointing piece should be installed at the fan connection with hose clamps to facilitate expansion and contraction.

The maximum recommended length air duct is 25ft and the maximum number of bends is 2. The minimum length is 18".

The location of the fresh air duct inlet must be where it will receive dust free clean air.

An inlet cap with bird screen must be fitted at the inlet of the duct.

If the duct inlet is located above the roof the underside of the inlet terminal must be at least 2ft above roof level and at least 10" above any projection on the roof within 7ft of the inlet.

Intake pipe, fittings and sealant are not furnished by the manufacturer. Refer fig 8a and 8b.

Figure 8.a Fresh Air Ducted Intake.

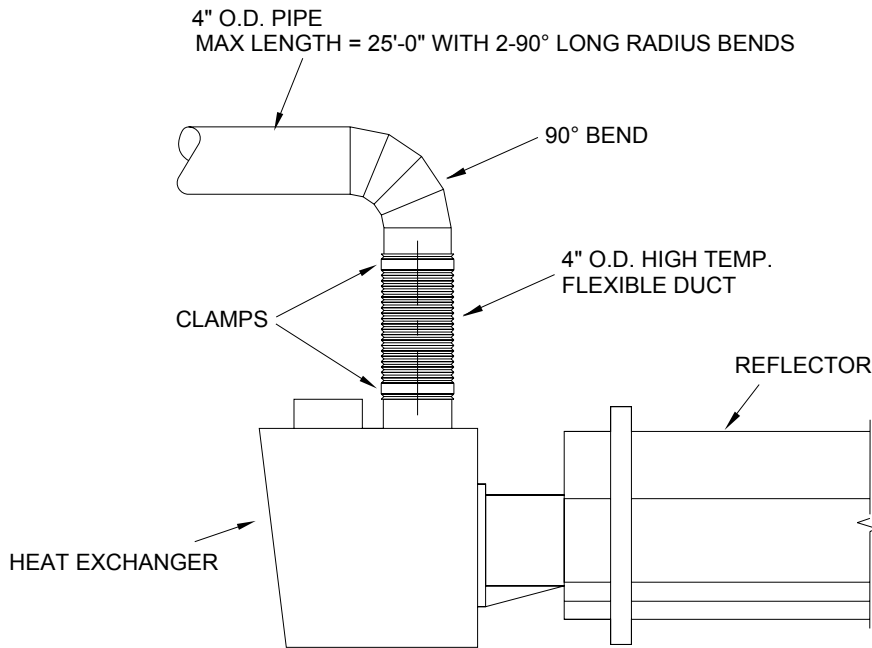
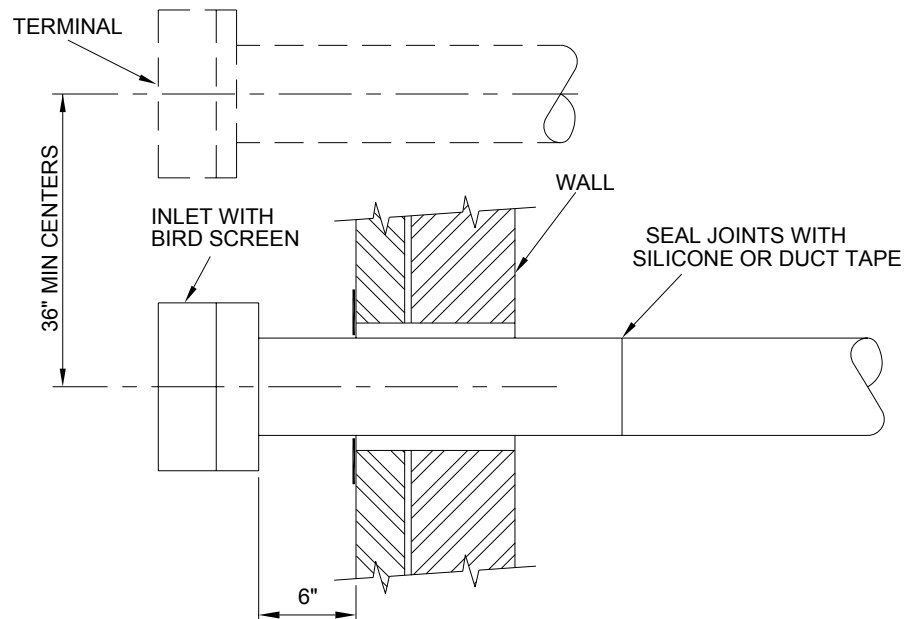


Figure 8.b Wall Terminal Intake Kit.



1.9 Vent and Combustion Air Inlet - Options

Dependent on the type of burner fitted to your heater it is possible to have configurations of vent and combustion air inlet options to those shown overleaf:

• **Option 1**

For vented products of combustion and no ducted air please refer to Figure 8.e.

• **Option 2**

For ducted air and products of combustion to ventilated area please refer to Figure 8.f.

• **Option 3**

For vented products of combustion and ducted air via concentric pipe please refer to Figure 8.g.

Figure 8.c Vertical Venting.

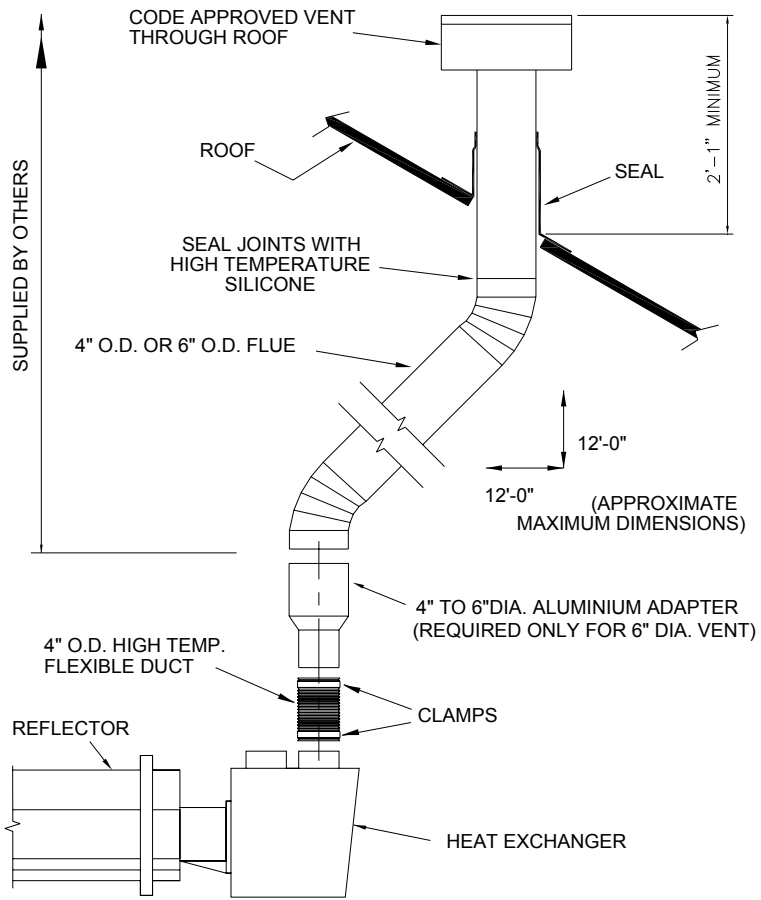
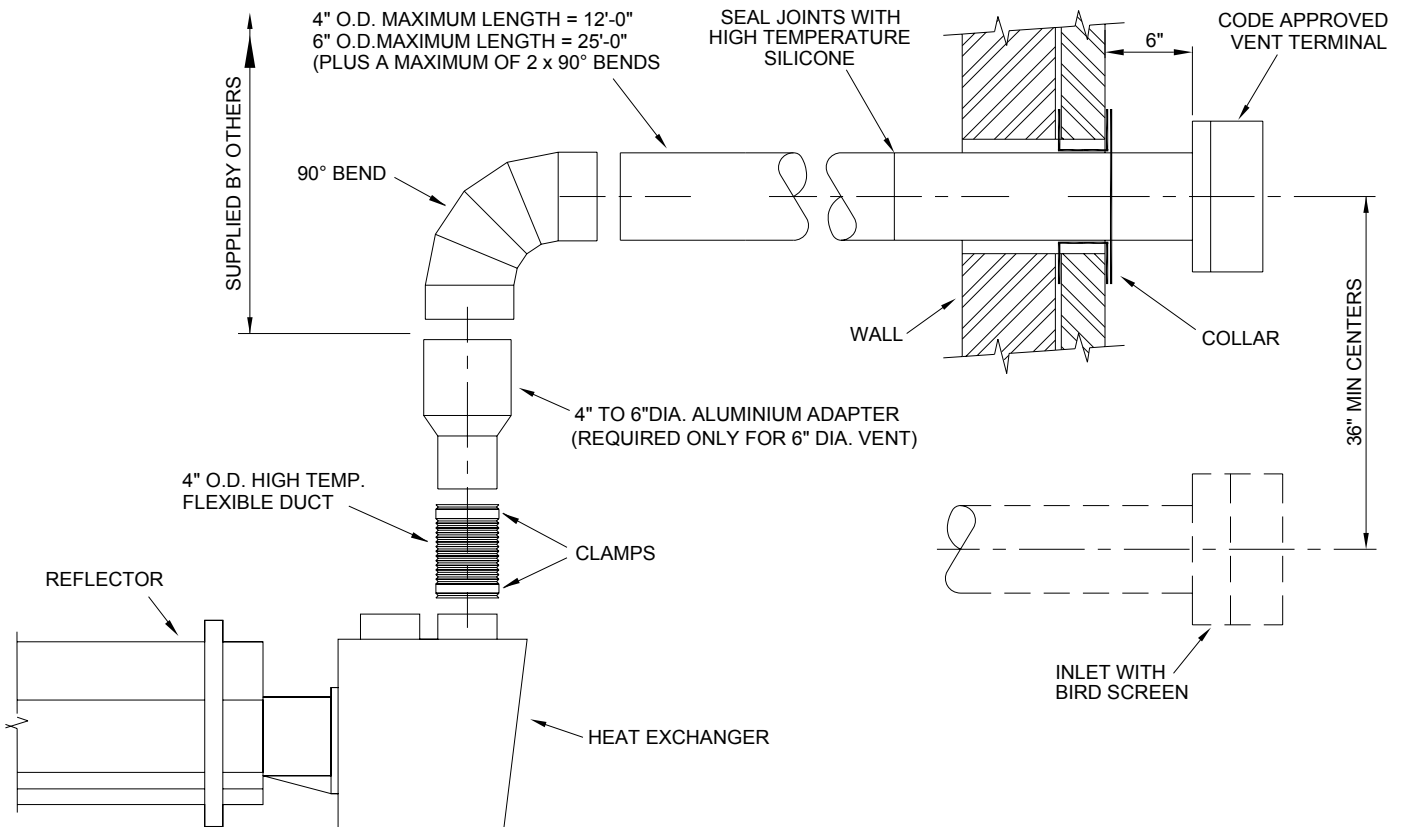
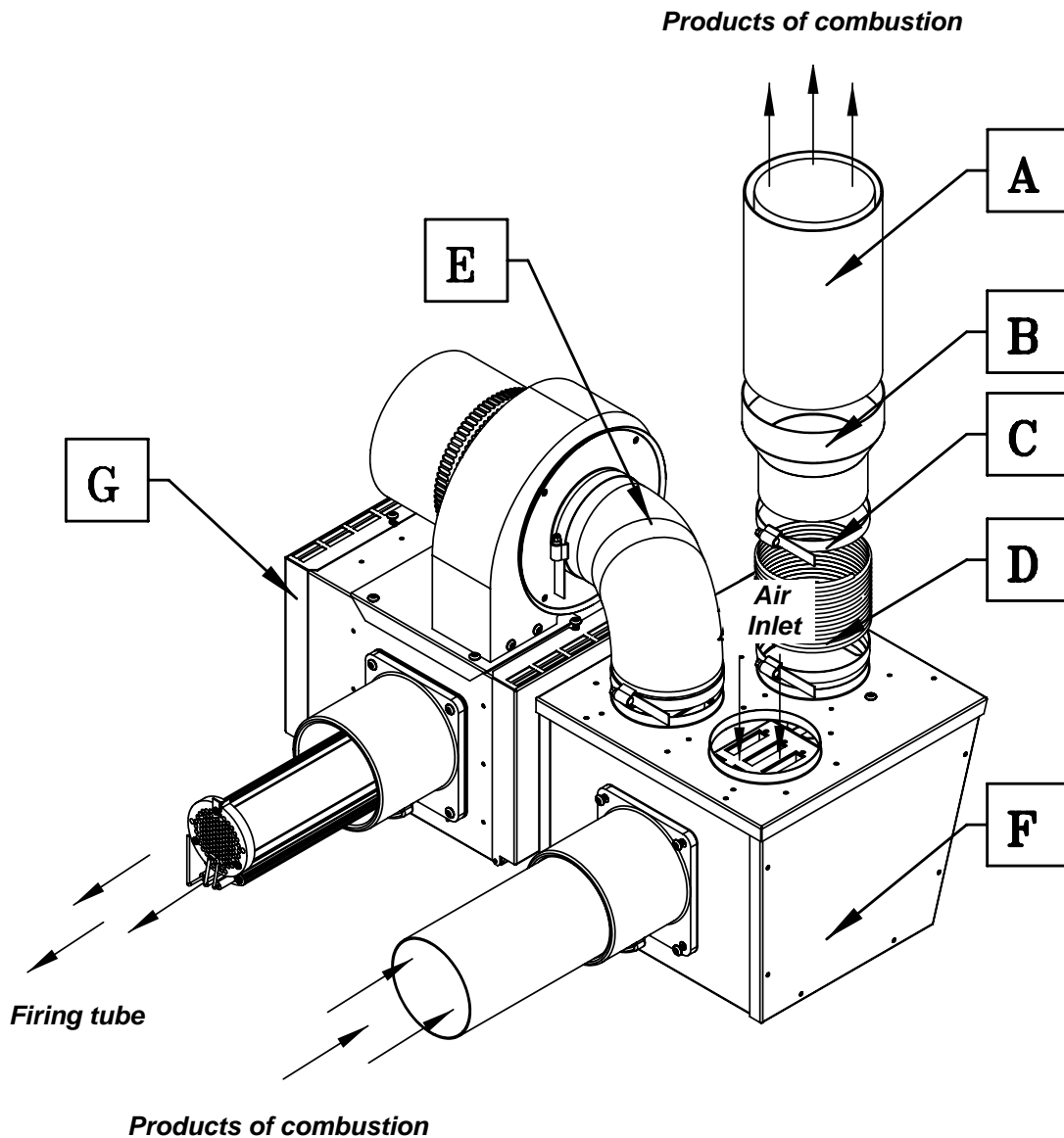


Figure 8.d Horizontal Venting.



Option 1 - Figure 8.e. Forced Burner with Heat Exchanger (Standard Vent)

For vented products of combustion and no ducted air



! If heaters are installed with no vent the ventilation instructions detailed in section 1.8 must be applied.

! Ducted air must be used in locations where there is airborne dust or where there is a polluted atmosphere e.g. Chlorinated Vapours.

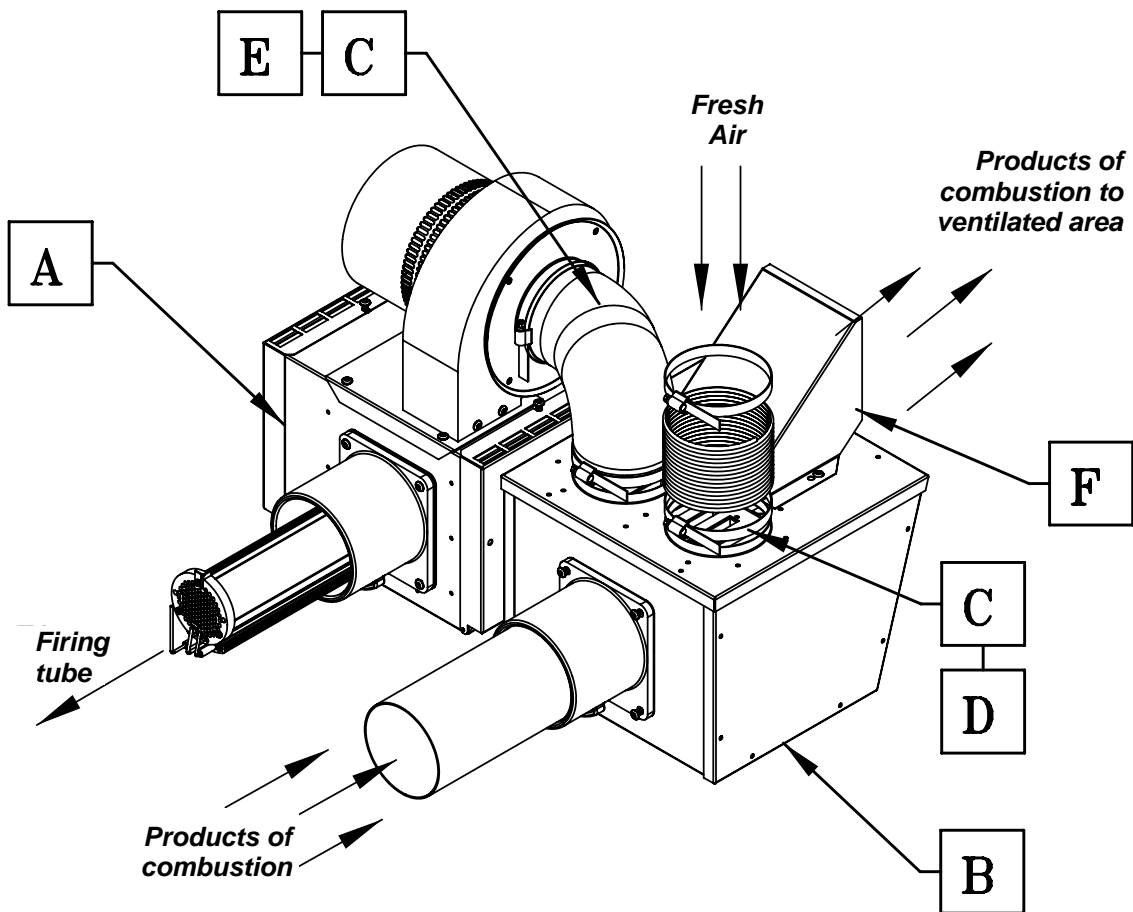
i Maximum length = 25ft
 Minimum diameter = 4in
 Maximum no of bends = 2

! Refer to section 1.8.3 for Maximum length of vent.

A	6ins Twin Wall Vent Pipe
B	6ins to 4ins Reducer
C	4ins Clip
D	4ins Flexible Vent
E	4ins Flexible Vent to Fan
F	Heat Exchanger
G	Forced Burner

Option 2 - Figure 8.f. Forced Burner with Heat Exchanger (No External Venting)

For ducted air and products of combustion to ventilated area



! if heaters are installed with no vent the ventilation instructions detailed in section 1.8 must be applied.

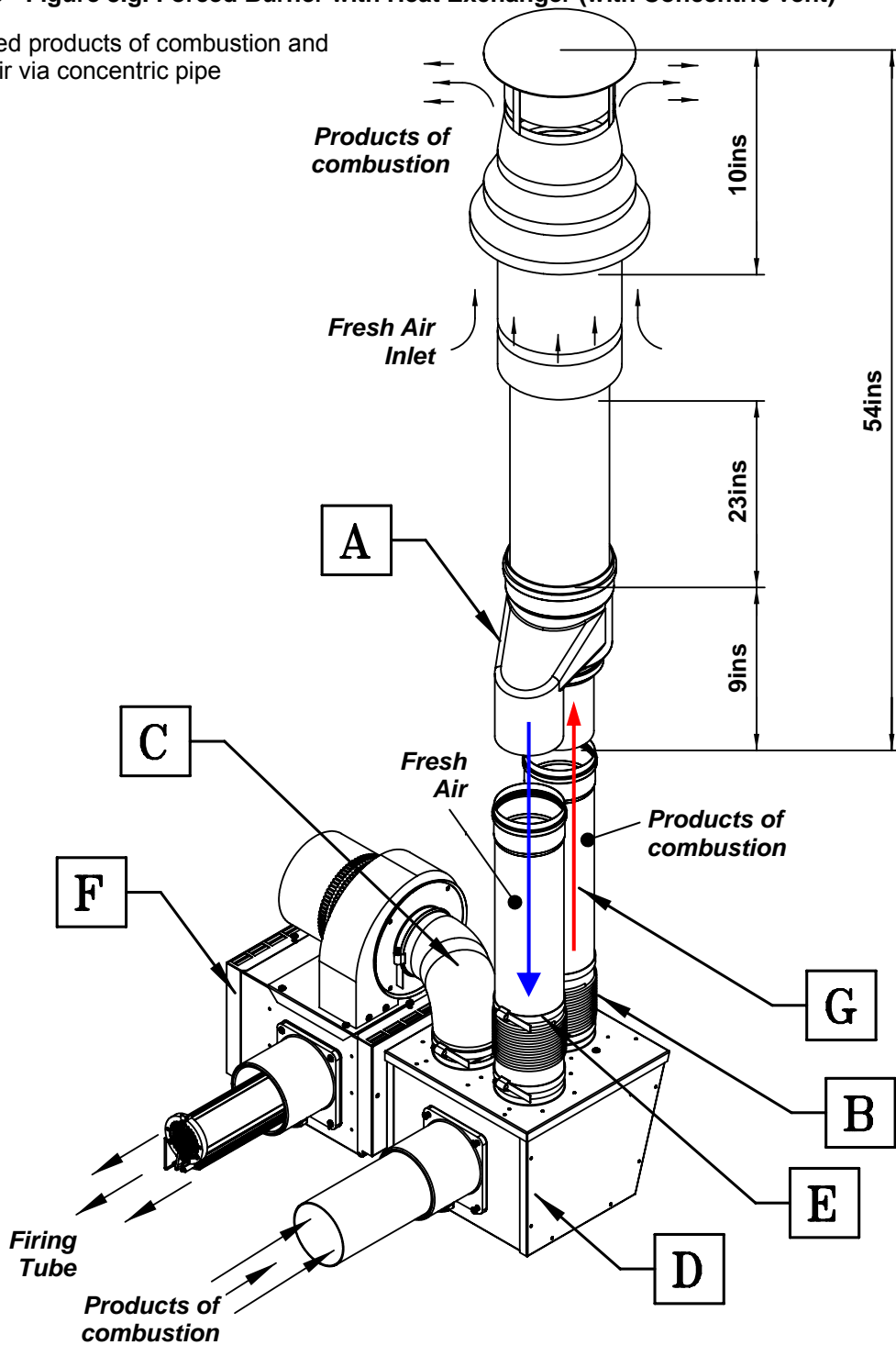
! Ducted air must be used in locations where there is airborne dust or where there is a polluted atmosphere e.g. Chlorinated Vapours.

i Maximum length = 25ft
 Minimum diameter = 4ins
 Maximum no of bends = 2

A	Forced Burner
B	Heat Exchanger
C	4ins Clips
D	4ins Flexible Vent
E	4ins Flexible Vent to Fan
F	Shroud for unvented heater installation

Option 3 - Figure 8.g. Forced Burner with Heat Exchanger (with Concentric vent)

For vented products of combustion and ducted air via concentric pipe



! if heaters are installed with no vent the ventilation instructions detailed in section 1.8 must be applied.

! Ducted air must be used in locations where there is airborne dust or where there is a polluted atmosphere e.g. Chlorinated Vapours.
 Maximum length = 25ft
 Minimum diameter = 4ins
 Maximum no of bends = 2

! Refer to section 1.8.3 for Maximum length of vent.

A	Concentric Vent Terminal
B	4ins Flexible to concentric vent
C	4ins Flexible to Fan
D	Heat Exchanger
E	4ins Clips
F	Forced Burner
G	Vent Extension optional (10ins/20ins/40ins)

1.10 Technical Details

Table 4 - Technical Details. All heaters to run on **Natural Gas (G20)**

No of Injectors	1
Gas Connection	½" N.P.T nipple.
Electrical Supply	120 volt 1 phase 60Hz
Vent size (in)	4" or 6"
Unitary Fan Motor Details	120 volt 1 phase 60Hz
Current Rating	1.2A MAX
Ignition	Electronic Program Start up with Spark Ignition

Burner Size	Nominal Gross Heat	Burner Head	Burner Orifice Plate	Injector	Injector Pressure
	BTU/Hr	Part No.	Part No.	Part No.	Inches WG.
VSXUS140	140,000	200988	201063-30	201007-30	4.5
VSXUS90	90,000		201063-26	201007-22	3.4

Burner Size	Combustion Fan Details		Pressure Switch	Heater Length
	Fan Type	Orifice Part No.	Part No.	(ft)
VSXUS140	2560-1	M101624-52	201676	17
VSXUS90	2576T	3133	201676	12

2. Assembly Instructions.

i **PLEASE READ** this section prior to assembly to familiarise yourself with the components and tools you require at the various stages of assembly. Carefully open the packaging and check the contents against the parts and check list.

The manufacturer reserves the right to alter specifications without prior notice.

i Please ensure that all packaging is disposed of in a safe environmentally friendly way.

i For your own safety we recommend the use of safety boots and leather faced gloves when handling sharp or heavy items. The use of protective eye wear is also recommended.

2.1 Tools Required.

i Suitable alternative tools may be used.

The following tools and equipment are advisable to complete the tasks laid out in this manual.



Saw Horses



Leather Faced Gloves



Phillips Screwdriver



Wrench Set




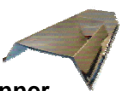










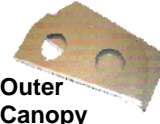









3/16" (5mm)
5/32" (4mm)
Allen wrenches



Tape Measure

2.2 Identification check list

COLOUR CODE	VSX90	VSX140
 Burner	1x	1x
 Heat Exchanger	1x	1x
 U Bend	1x	1x
 Inner Reflectors	2x	3x
 Outer Canopy	2x	3x
 Brackets	3x	4x
 M6 Mudwasher	12	16
 M6 Washer	4	6
 M6 Full Nut	6	10
 M6 x 35 Setpin	4	6
 M4 x 10 Pozi Setpin	7	8

COLOUR CODE	VSX90	VSX140
 Inner End Caps	2x	2x
 Outer Canopy End Caps	2x	2x
 Tubes	2x	2x
 Turbulators	2x	3x
 Couplers	2x	2x
 M4 Full Nut	1x	2x
 M4 Washer	7	8
 No.5 Torque Screw	13	14
 M6 x 15 Setpin	2	4
 M8 Full Nut	16	22
 M8 U Bolt	6	8

2.3 Prior to assembly

- Ensure the area in which you are working is safe and clear of obstructions.
 - Identify with the components in the check list and in which order they will be assembled.
 - Arrange the trestles* in a straight line to allow for length of tubes.
 - Remove all protective plastic from underside of Stainless Steel Reflectors / inside of End Caps.
- * if saw horses cannot be located, ensure any alternative is sound and can carry the heater weight.



Methodology: To cater for the expansion of the firing leg, all U bolts on the firing leg (except the one closest to U bend) are to be loose as described below. All reflectors, tubes, brackets and canopies are bolted together.

2.4 Step by step installation.

2.4.1 TUBES & TURBULATORS.

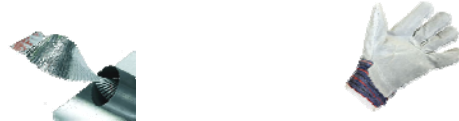
- 1 Locate and position tubes on trestles. After deciding which end will have the burner, mark out the position of the first bracket as shown in the assembly drawings section. Slide brackets over tubes as shown.

2x 2x



- 2 Locate and insert turbulator(s) into tube(s) ensuring the correct length and quantity are inserted into the correct tube. See assembly drawings section for location & length.

2x 3x

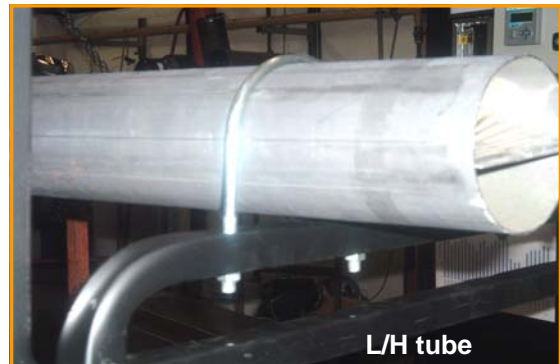


CAUTION — SHARP EDGES!

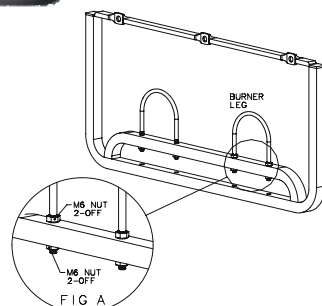
2.4.2 BRACKETS, U BOLTS & U BEND.

- 3 Fit the M8 U bolts over the tubes into the holes in the bracket & loosely secure with M8 nuts & washers, noting that all the brackets on the firing tube (right hand) except the bracket adjacent to the U bend should have nuts & washers on both sides of the bracket to allow bracket to be tightened whilst still allowing a 3mm gap for expansion between the tube & U bolt. See assembly drawings section Fig.A.

3x 4x



DO NOT tighten any of the nuts at this stage.



4 Working at the opposite ends of the tubes to the burner, locate & position two couplers so that the socket heads are facing outwards & the pre-fitted bolts in the couplers line up with the locating holes in the tubes. **Do not fully tighten at this stage.**

2x 2x



5 Slide U bend into the open end of the couplers ensuring the pre-fitted bolts engage in the pre-cut holes in the U tube section. Tighten all four clamping bolts to provide a tight grip between tubes & U tube section.

1x 1x



2.4.3 REFLECTORS

6

i Remove protective film before starting.

The reflectors supplied all have the same hole positions, however, each end reflector should be positioned with the holes for the end caps (position arrowed) outermost.

Starting at the burner end, slide the reflectors through the brackets until they are all roughly in position along the heater, referring to the assembly diagram showing overlaps. Measure the distance between the end of the burner end tubes & the centre of the end bracket, **This should be 6" (150mm)**, slide bracket along tubes to adjust, then tighten U bolts on the end bracket.

2x 3x



! CAUTION — SHARP EDGES!

7 Slide end reflector so that the innermost slotted holes line up with 1st bracket fixing holes, then fix in place using M6 x 35mm pins, washers & nuts.

2x 2x



8 Slide 2nd bracket to line up with innermost slotted hole in 1st reflector, & bolt together using M6 x 35mm pins, washers & nuts. Bolt 1st & 2nd reflectors together using end elongated holes in each.

4x 4x



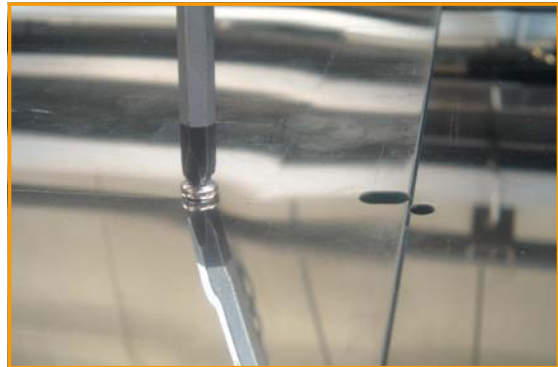
9 Repeat this procedure referring to the assembly diagram for quantities used on specific models, but noting that the final bracket is **not** bolted to the reflector. (See photo)

! At this stage all the U bolts should be fully tightened.



10 Locate M4 pins, washers & nuts into holes in overlapping reflectors as shown.

1x 2x
1x 2x
1x 2x



2.4.4 END CAPS

11 Using M4 setpins & washers fix the blank end cap beneath the the reflector profile at the U bend end with the **flanges facing outwards**.

3x 3x
3x 3x
2x 2x



12 Using M4 setpins & washers fix the 'cut out' end cap beneath the reflector profile at the burner end with the **flanges facing outwards**.

3x 3x
3x 3x



2.4.5 CANOPIES

13 Remove protective film before starting.

Slide the outer canopies over the reflectors from the U bend end ensuring correct location in reflector profile. Line up burner end canopy flush with burner end reflector. Overlap canopies as shown in the assembly diagram.

2x 3x



! CAUTION — SHARP EDGES!

14 Adjust canopies so that the holes on top align with each other as detailed in the assembly instructions. Locate and fix one No.5 torque screw on every canopy overlap.

1x 2x



2.4.6 CANOPY END CAPS

15 Locate 6 off No.5 torque screws. Position the blank canopy end cap with the end cap flanges facing **inwards**, beneath the canopy profile at the U bend end & fix with screws. Repeat procedure for 'cut-out' canopy end cap, again ensuring the flange faces **inwards**.

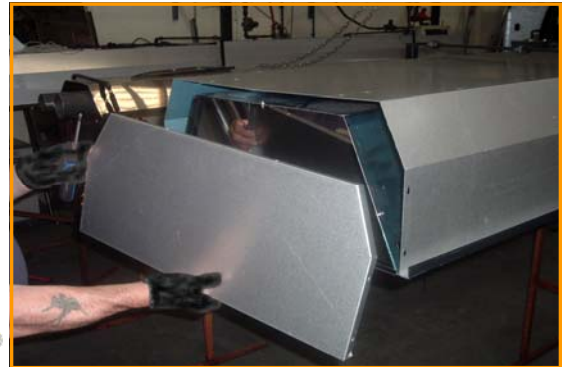
2x 2x



12x 12x



! CAUTION — SHARP EDGES!



2.4.7 GENERAL

16 The heater assembly is now complete and can now be installed. We would recommend that the burner and heat exchanger be assembled once the heater has been installed in the roof space.

1x 1x



1x 1x

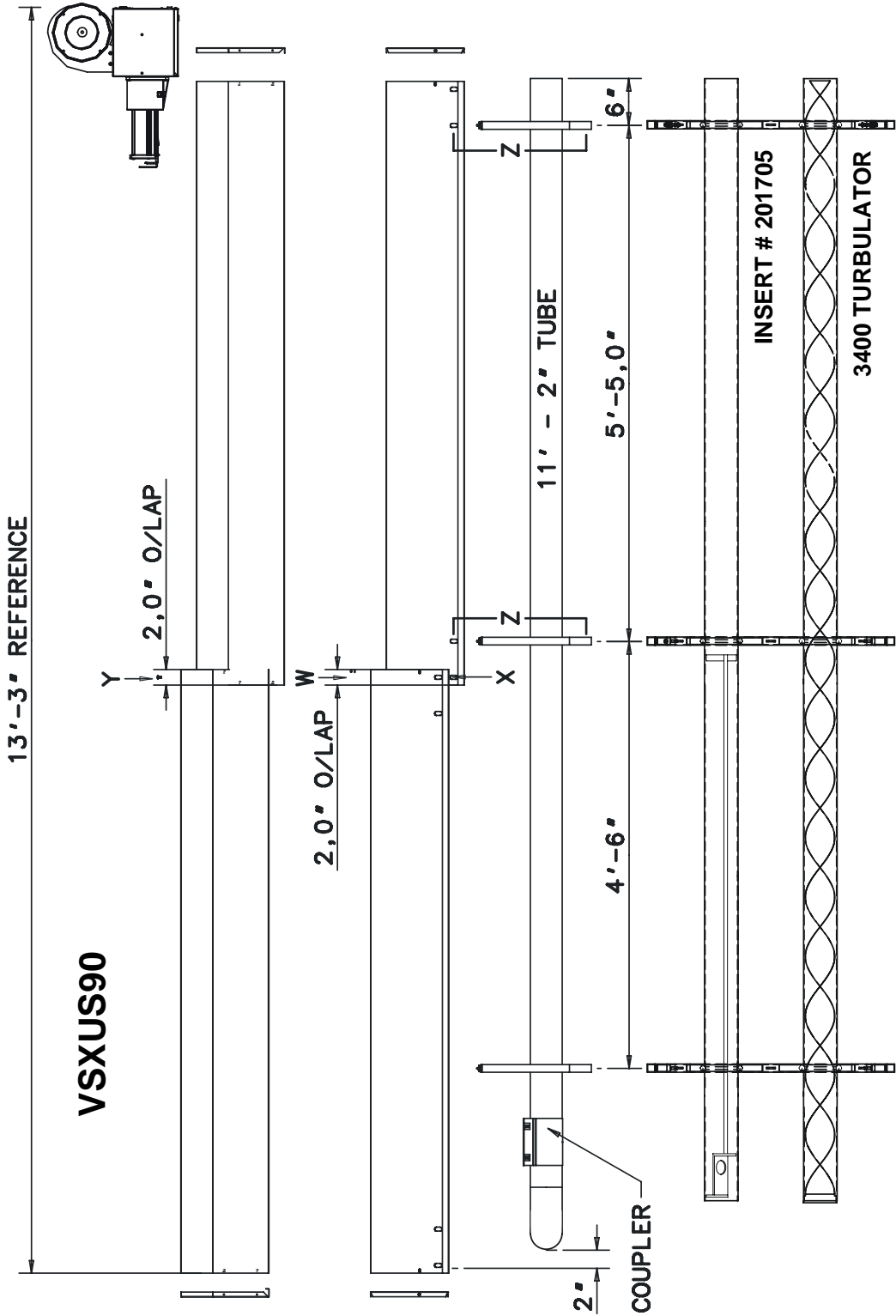


Figure 9. VSXUS Heater Assembly

2.4.8 Detailed Assembly Drawings

The following pages show the technical dimensional details of the VSXUS range of heaters.

Please note the heater type, length and reference number from the delivery/advice note before identifying the correct model drawing.



VSXUS140

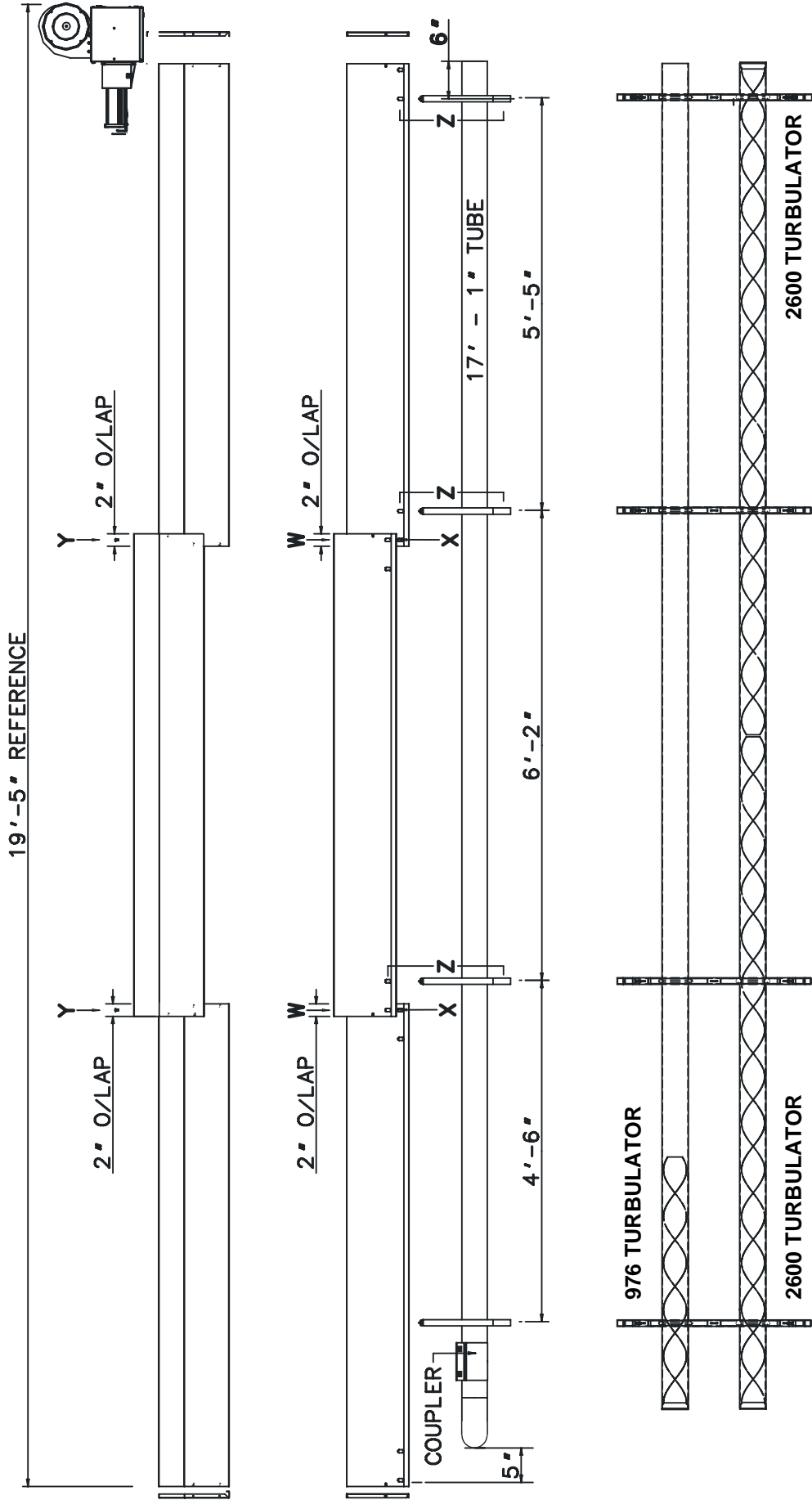
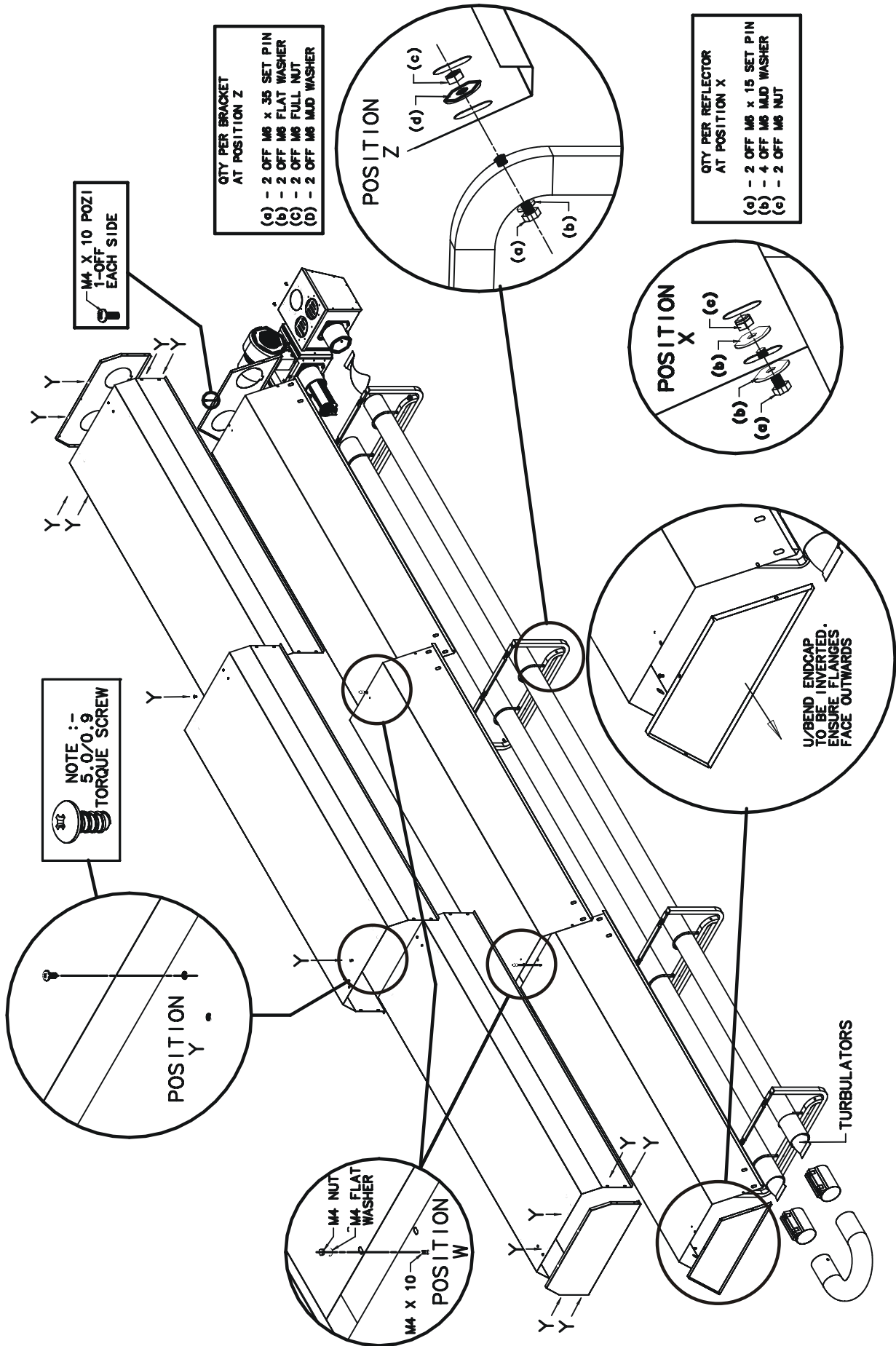


Figure 10. VSXUS Heater Breakdown (3 module VSXUS140 shown)



3. Start Up Instructions.



These appliances should be commissioned by a qualified mechanical contractor.

3.1 Tools Required.

The following tools and equipment are advisable to complete the tasks laid out in this manual.



Suitable alternative tools may be used.



Leather Faced Gloves



Phillips Screwdriver



Small Flat Head Screwdriver



Large Adjustable Wrenches for fitting Of Gas Flex.



1/2" Spanner



5/32" (4mm) Allen Wrench



Manometer



Multimeter

3.2 Start Up procedure

Inspect installation and ensure that it has been carried out in accordance with these instructions. Remove burner and inspect the electrode assemblies ensuring these are securely fixed and all electrical connections securely made.

Re-fit the burner ensuring that it is correctly positioned and the screws are fully tightened. Ensure that electrical and gas supplies are isolated.

The gas supply should be purged and tested for soundness in accordance with local and National Safety codes.

Open isolating gas valve and test gas connections for soundness using soap solution.

Open the control housing door by unscrewing the securing screw. Ensure all internal components are securely fixed and all connections securely made.

Open the manual gas valve outside the control housing

Switch on the electrical supply to start the heater and observe the correct start up sequence. Ensure that the setting of any time switch and thermostat are such that the heating system will be required to operate.

The fan will start to run and the 'power on' lamp will illuminate. Safe-start checks are carried out automatically. After the fan has run up to full speed and a satisfactory pressure condition has been established, the ignition sequence will commence. The spark ignition will be energized

producing a spark at the ignition electrode. The gas solenoid valve will at the same time be energised and the 'burner on' lamp will illuminate. If the ignition is successful the flame is detected by the flame sensing probe and the 'burner on' lamp will remain on.

If ignition is unsuccessful the gas valve will close and the spark ignition de-energized after approximately 10 seconds. For approximately 10 to 20 seconds the fan will purge the system then re-ignition will be attempted. After 2 further attempts at ignition the control unit will 'lock-out', the 'power on' lamp will remain illuminated and the fan will continue to run. To reset after 'lockout' switch off the power supply to the system and wait 2 minutes. Then turn the power on. If repeated 'lockout' occurs investigate the cause.

Set burner gas pressure as follows:

Switch off the power supply to the heating system. Connect a 'U' tube manometer to the pressure test point provided on the combination gas control valve. Remove the cover from the pressure regulator revealing the adjustable screw. Start the heater and using a suitable screwdriver adjust the pressure regulator, turning the screw clockwise to increase the pressure or counter-clockwise to decrease the pressure. Set the pressure to appropriate inches w.c. from the table of gas pressures and orifice plate dimensions for correct heater description. Switch off the power supply to the heating system. Disconnect 'U' tube manometer, then securely replace screw in pressure test nipple.

Check the operation of the flame safeguard equipment as follows:

With the heater running normally, switch off the gas supply at the shut off valve. The heater

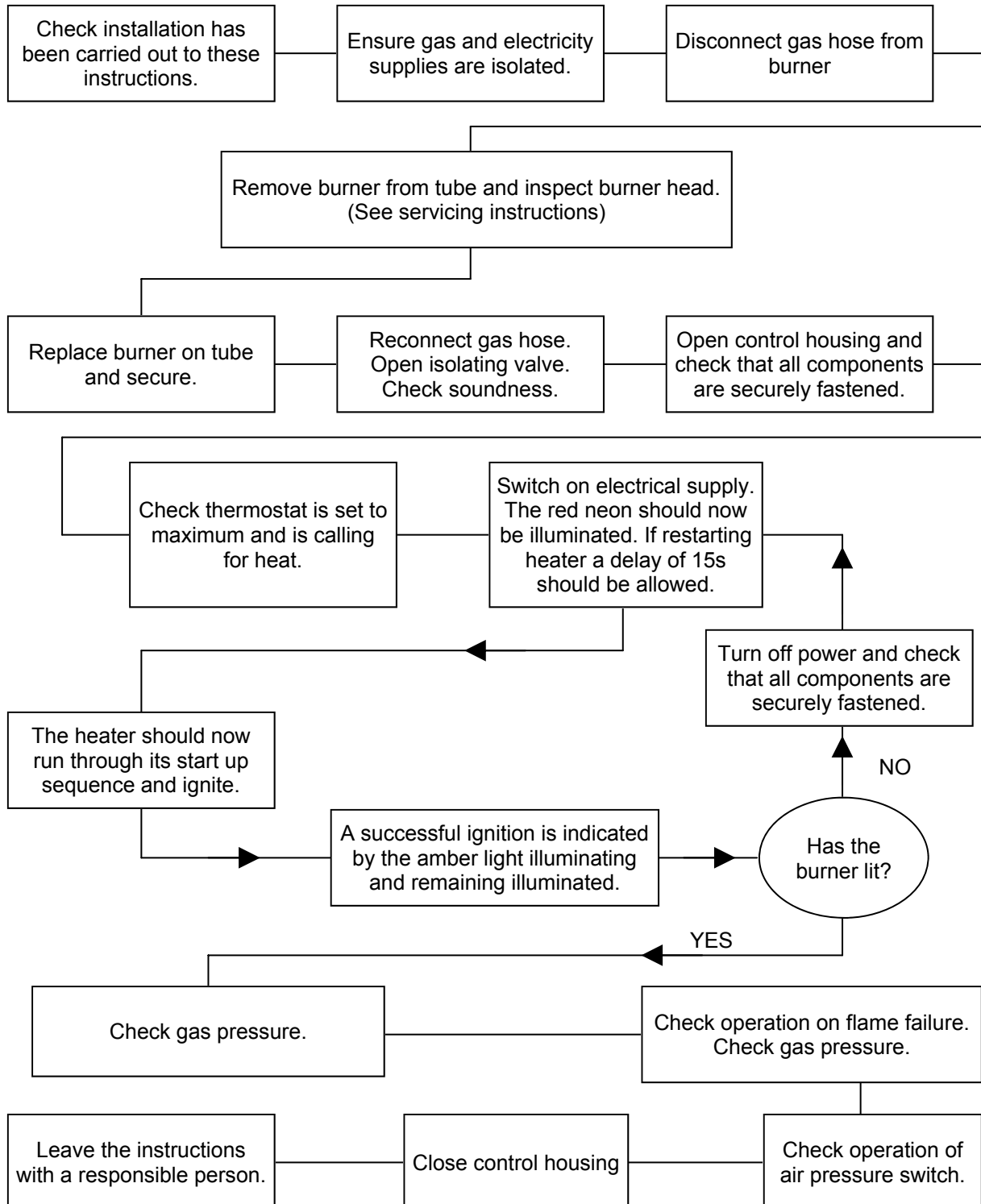
should attempt to relight and if the gas valve has been left off 'lock-out' should occur indicated by the 'power on' lamp being illuminated and fan running, but the 'burner on' lamp being off.

With the heater running normally, pull off the silicone rubber tube connecting the vacuum switch to the combustion chamber. Within 4 seconds the burner should shut off. Then replace the tube securely and observe that the heater proceeds to ignite in the normal way.

Check the operation of the pressure proving switch as follows:

Close the controls door securing it with the screw.

Commissioning chart



4. Servicing Instructions.

! These appliances should be serviced annually by a competent person to ensure safe and efficient operation. In exceptional dusty or polluted conditions more frequent servicing may be required. Servicing work should be carried out by a qualified mechanical contractor.

4.1 Tools Required.

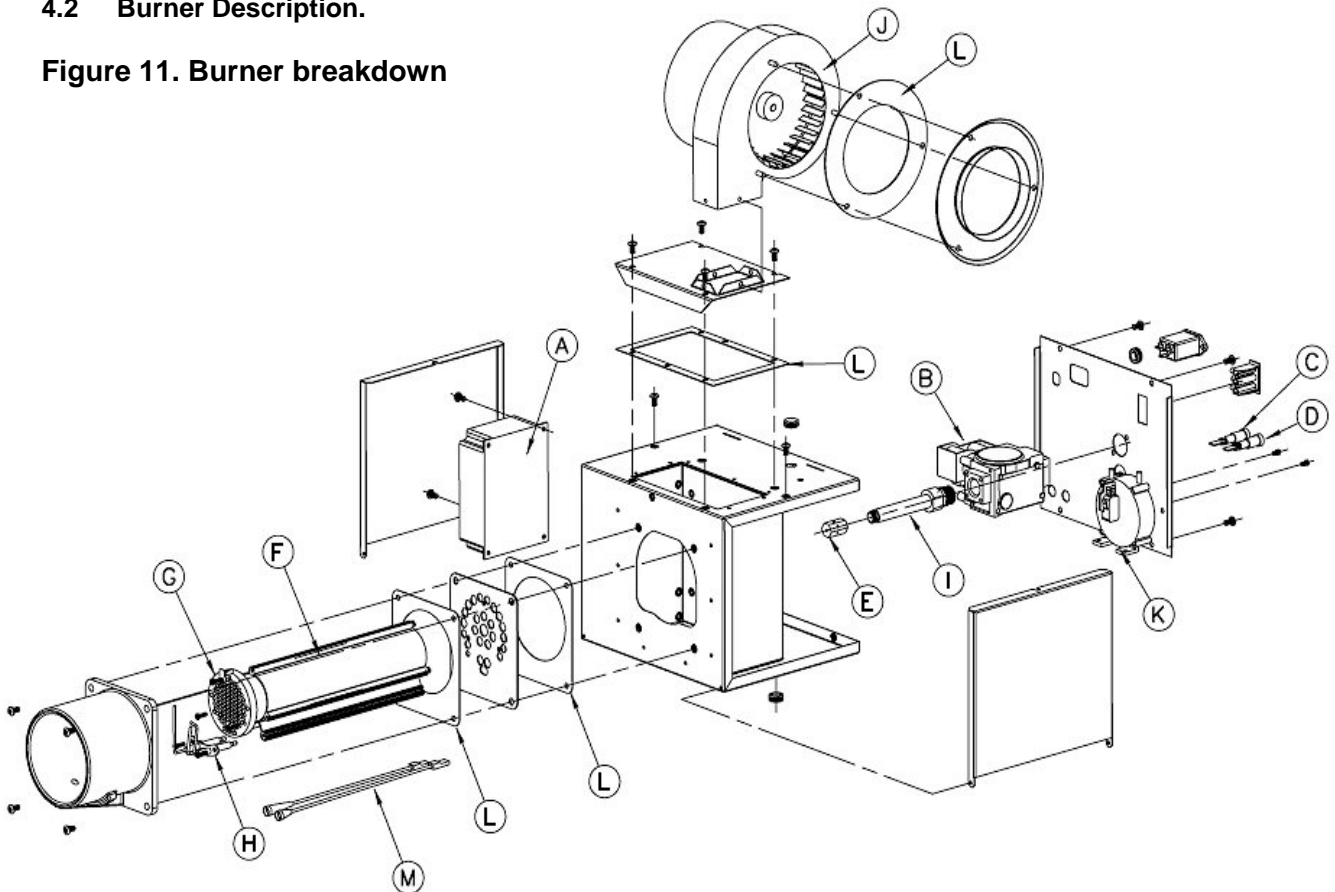
i Suitable alternative tools may be used.

The following tools and equipment are advisable to complete the tasks laid out in this manual.




4.2 Burner Description.

Figure 11. Burner breakdown

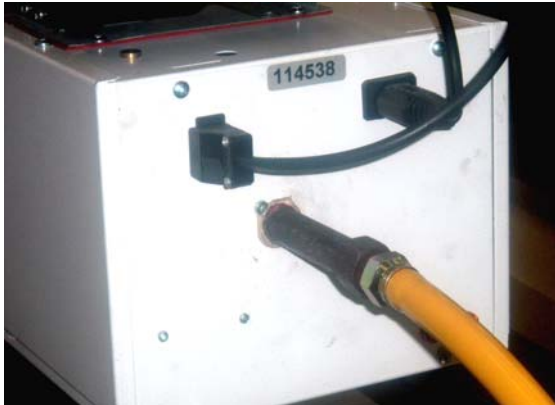


A	Ignition Controller	H	Ignitor Assembly
B	Gas Valve	I	Jet Carrier
C	Burner On Amber Neon	J	Combustion Fan
D	Power On Red Neon	K	Pressure Switch
E	Injector	L	Gaskets
F	Burner Tube	M	Burner Head Wiring Harness
G	Pepperpot Head		

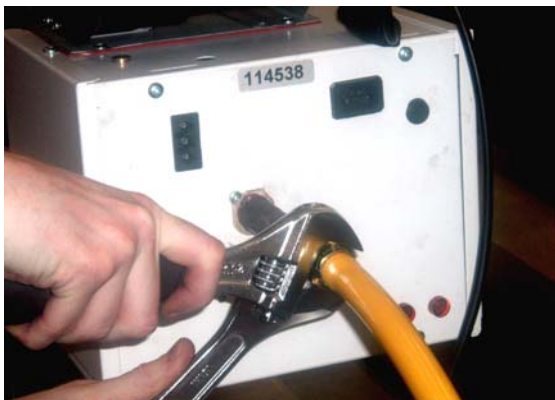
4.3 Burner Removal

 Step 1 Isolate power and gas supplies.

Step 2 Unplug the power connectors.



Step 3 Detach the gas supply as shown below, taking care to support the burner connection.




Step 4 If ducted air is connected, slacken hose clip and remove the flexible hose from the burner.



Step 5 slacken the jubilee clip attaching the pre-heated air hose to the heat exchanger and remove the flexible hose from the burner.



Step 5 Slacken the set screw on the burner support casting to enable the burner to be removed from the radiant tube.

 Step 6 Remove the burner and position the burner in a safe area to prevent the burner or components attached to the burner from falling to the ground.

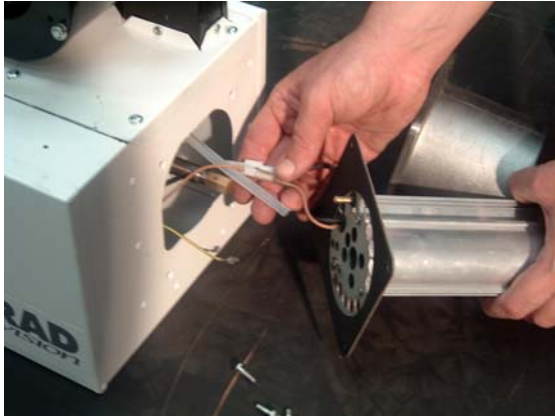


4.4 Burner Gas Injector Servicing


Step 1.a Remove the burner support casting and gasket.



Step 1.b The burner head assembly can be disconnected by separating the connectors of the ignition lead assembly and removing the pressure switch silicon tube.



Step 2 The gas injector can be inspected and replaced if contaminated or blocked.

 When replacing the gas injector ensure approved thread sealant is used.

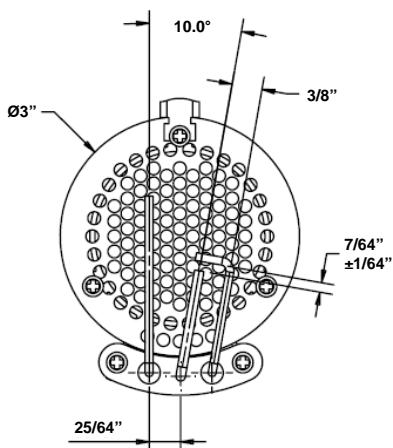


Step 3 Reconnect ignition leads and silicone tube to test nipple. Refit gasket and support casting.

4.5 Burner Head and Electrode Servicing

Step 1 Check the pepper pot burner head for contamination. If necessary this can be removed. See below. This can be cleaned together with the Inside of the burner head.

Step 2 The pepper pot burner head can be



replaced ensuring the 5 holes on the outer ring are aligned alongside the probes.

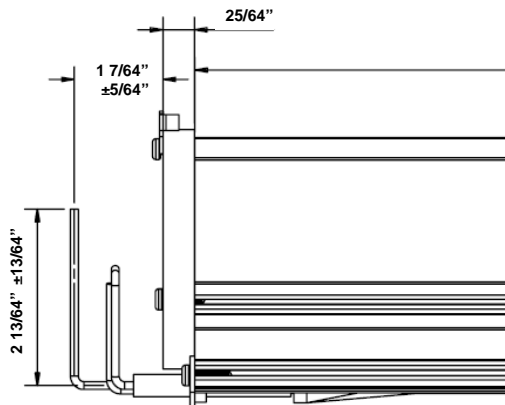
Step 3 The condition of the igniter assembly can be checked for deterioration. However, we advise replacement at each service to ensure continued reliability. Detach the electrode assembly from the burner head by removing the two screws and separating the igniter lead connectors.



Step 4 Refit the electrode assembly and ensure the connections are secure to prevent arcing of the spark electrode.

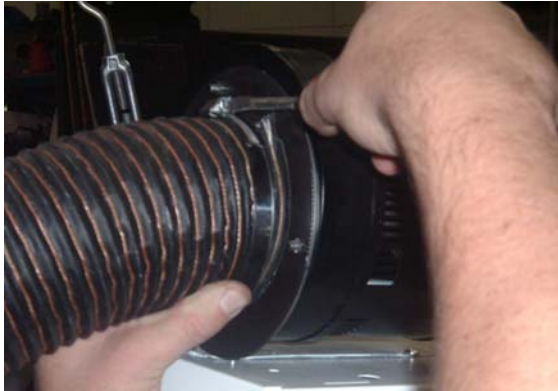
Step 5 Check the positions and spark gap as shown below.

Step 6 The burner assembly is ready to refit after servicing the combustion fan and the radiant tube assembly.



4.6 Combustion Fan Assembly

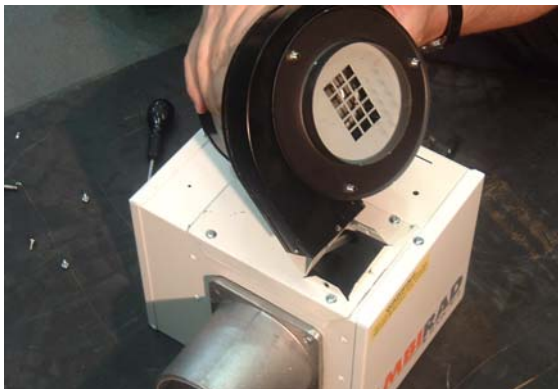
Step 1 If ducted air is fitted, slacken hose clamp and remove the flexible hose from the fan.



Step 2 Remove fan screws and unplug from burner box.



Step 3 The combustion fan can now be detached.



Step 4 Remove the fan orifice plate spigot and spinning.

Step 5 Inspect the impeller and remove any dust with a soft brush.

Step 6 Remove any dust from fan scroll and from around the motor.



Step 7 Ensure the impeller rotates freely.

Step 8 Refit components.

4.7 Radiant Tube Servicing

Step 1 Brush any dust from the exterior of the tubes.

Step 2 Inspect the fan and burner tubes visually. If the tubes appear clean, skip to servicing the reflector.

Step 3 Remove the U bend.



Step 4 Withdraw the turbulators from the appliance. Carefully noting their condition and position. Replace turbulators if necessary.



Step 5 The turbulators should be cleaned with a soft brush.



Step 3 If required the interior of the tubes can then be cleaned using an industrial vacuum cleaner or by using long poles and a scraper.

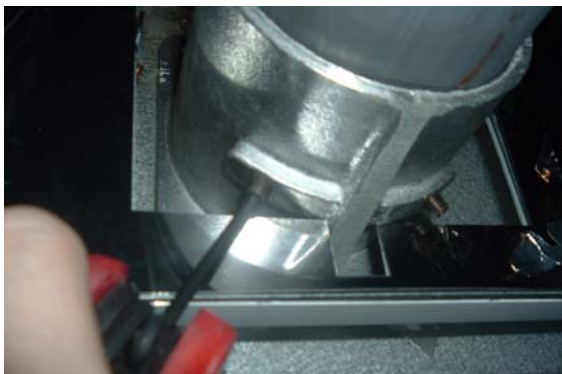
Step 4 Refit components.

4.8 Heat exchanger Servicing

Step 1 Remove the vent connections



Step 2 Slacken casing support screws and remove heat exchanger from the radiant tube.



Step 3 Remove any dust and dirt from the heat exchanger & refit.

4.9 Reflector Servicing

The condition of the reflectors should be noted.

If necessary the reflectors can be cleaned with a mild detergent. This can significantly improve the efficiency of the appliance.

4.10 Sweeping of Vent

Inspect the fresh air inlet duct and vent to ensure they are free from any blockage or obstruction. The air inlet terminal and vent terminal should be inspected to ensure they are not liable to obstruction.


4.11 Recommissioning After Service

After servicing of the heater has been undertaken, it will be necessary to re-commission the heater as detailed in Section 11 of these instructions.

5. Spare Parts.

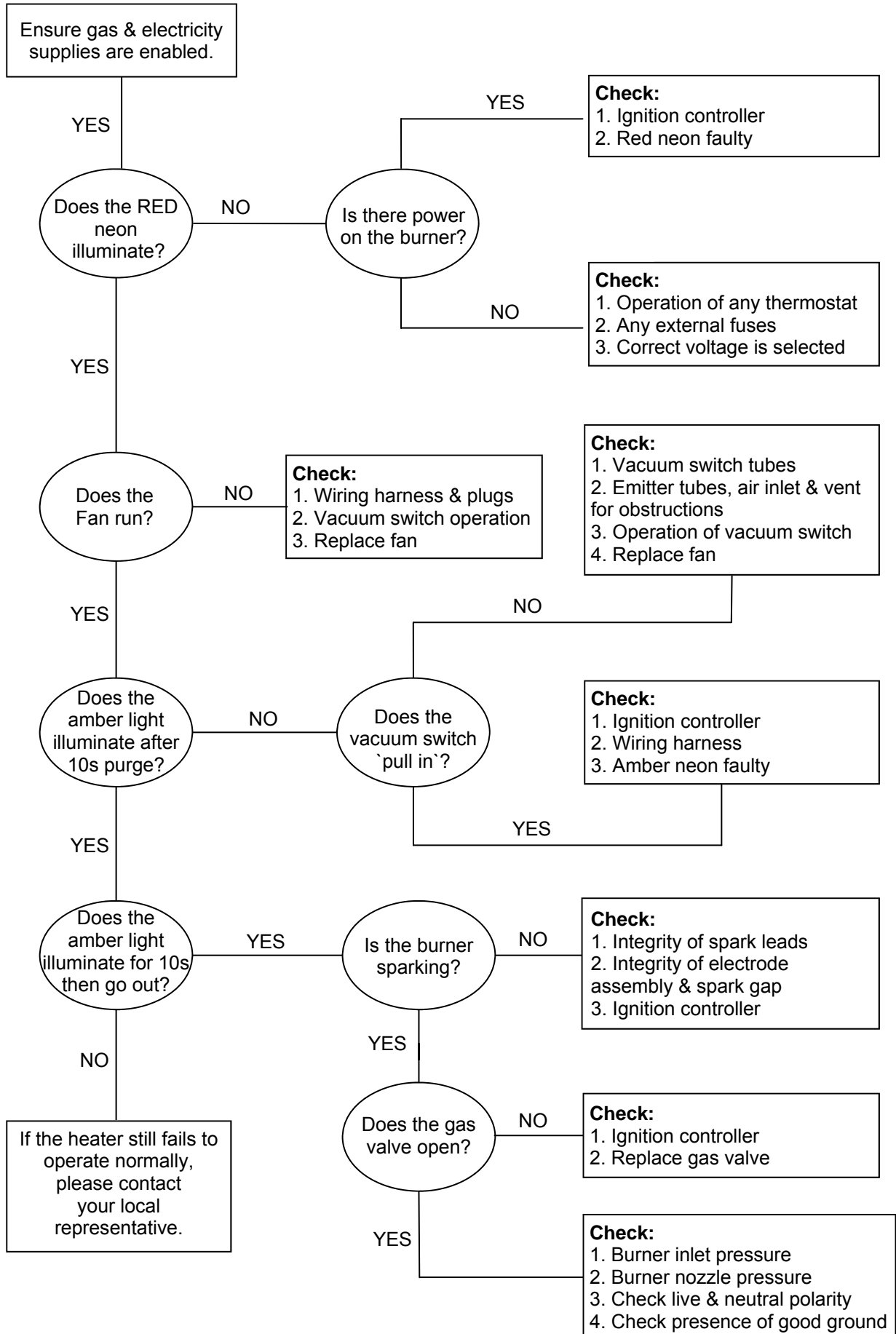
Required Spares

In order to aid troubleshooting and servicing we recommend that the components shown in this section should be stocked.

 **Note** Any spare part components that are not approved by AmbiRad could invalidate the approval of the appliance and validity of the warranty.

Item	Description	Part No.	Item	Description	Part No.
	Ignition Controller	3256-11		Pressure Switch	201676
	Valve Twin sol reg	201706		Amber Neon (Burner On)	2181
	Pepperpot Head	200988		Red Neon (Mains On)	2176
	Ignitor Assembly	201284		Combustion Fan 140 90	2560-1 2576T
	Burner Tube	200358		Gasket Set	201488
	Injector	See section 1.11		Ducted Air Hose	201321
	Jet Carrier	200420		Hose Clamp	7541
	Cables:			Tube Insert VSXUS 90 ONLY	201705
	Spark Electrode (black)	900225-2		Turbulator VSXUS 90	200015T
	Rectification lead (purple)	900225-3		VSXUS 140 short	6618T
	Earth lead (green/yellow)	900225-1		VSXUS 140 long	6619T

6. Troubleshooting Guide.



7. Replacing Parts.

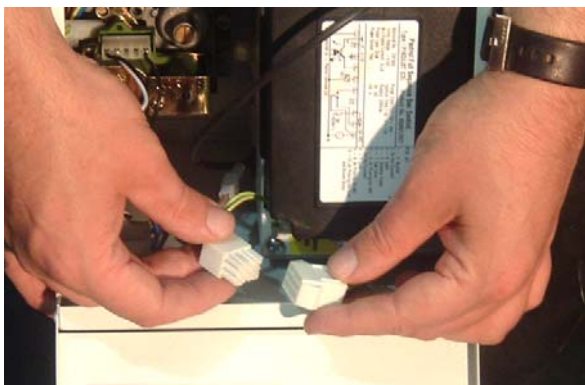


Turn off gas and any electrical supplies to the heater before starting repair work.

7.1 Burner Controller Replacement

Step 1 Slacken screw in burner lid and open the right hand burner access door.

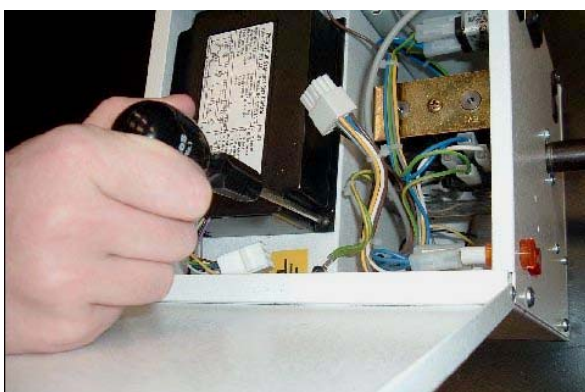
Step 2 Disconnect burner controller from the wiring harness.



Step 3 Disconnect the HT Lead from burner controller



Step 4 Remove the two screws attaching the controller to the burner and remove.



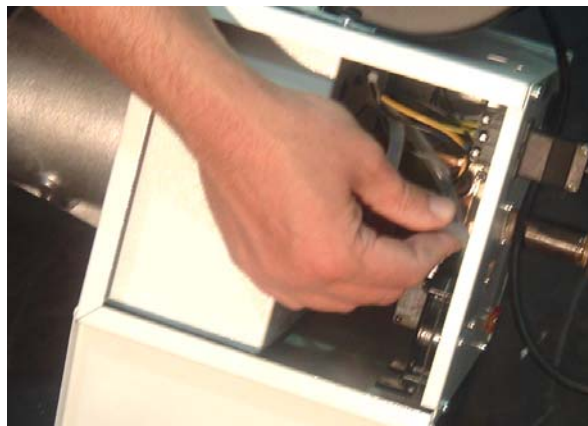
Step 5 Fit new burner controller

Step 6 Refit leads

Step 7 Test product and close access door.

7.2 Air Pressure Switch Replacement

Step 1 Open left hand door. Disconnect the two silicone impulse tubes.



Step 2 Remove the two screws as shown below.



Step 3 Remove electrical connections. The air pressure switch can now be removed.

Step 4 Fit the new air pressure switch ensuring the impulse tubes are connected as shown below.

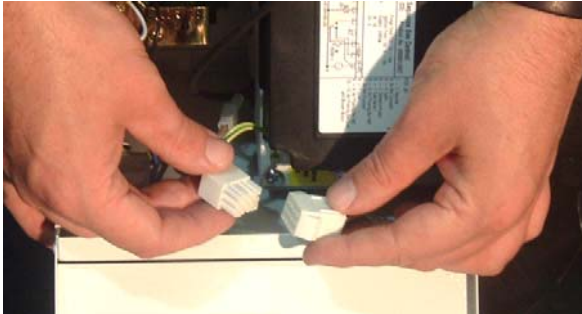


Step 5 Test product and close access doors.

7.3 Gas Valve Replacement

Step 1 Remove the burner assembly as described in the Servicing Sections.

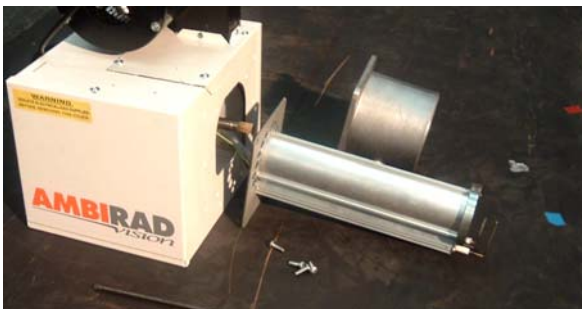
Step 2 Open the right hand access door and detach the burner controller from the wiring harness.



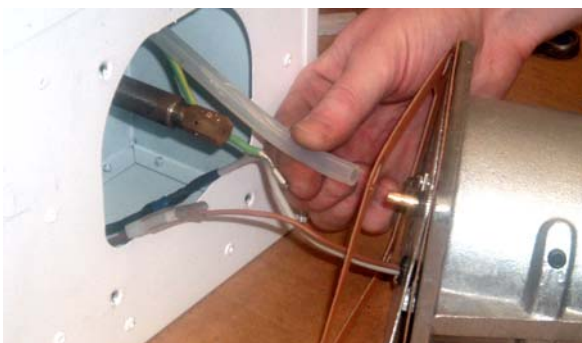
Step 3 Open the left hand access door and detach the impulse hoses from the air pressure switch.



Step 4 Remove the 4 screws holding the burner head onto the burner assembly.



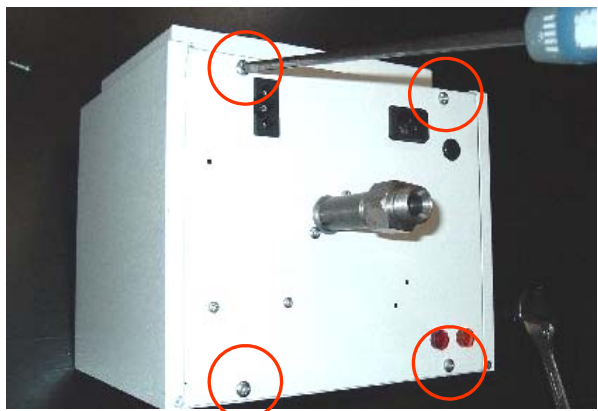
Step 5 The burner head can now be detached by disconnecting the impulse tube and the burner head wiring.



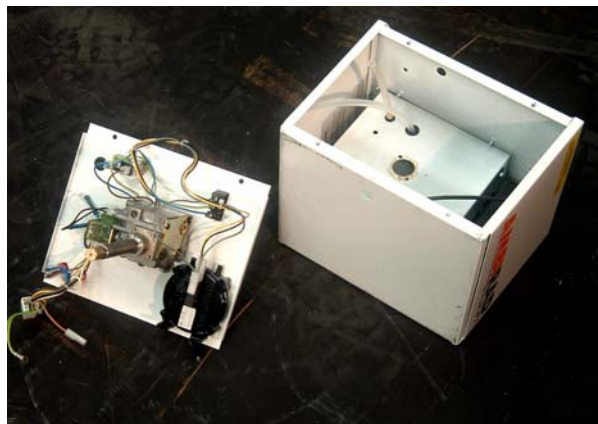
Step 6 Detach the two screws holding the front of the gas valve.



Step 7 Remove the four screws holding the rear burner plate in position.



Step 8 Remove the rear plate.



Step 9 The jet carrier, gas inlet, and wiring harness can now be detached from the gas valve.

Step 10 The two screws retaining the gas valve can then be removed.

Step 11 The gas valve can now be replaced.

Step 12 Refit all components.

Step 13 Set pressures and ensure reliable burner performance.

Step 14 Test product and close access door.

THIS PAGE HAS INTENTIONALLY BEEN LEFT BLANK.

8. User & Operating Instructions.

AmbiRad is the manufacturer of a series of tubular infra-red heaters designed for overhead heating of industrial and commercial buildings. Individual heating units are suspended from the roof or mounted at an angle on the wall



- 1. This appliance must only be installed by qualified craftsmen in accordance with the requirements of local and National Codes.**
- 2. This appliance must be grounded in accordance with the National Electrical Code ANSI/NFPA No.70.**
- 3. Never rest anything, especially ladders against the heaters.**

8.1 To Start the Heater

1. First ensure that the gas supply to each heater is turned on by opening the main gas shut off valve.
2. Ensure that the setting of any time switch and thermostat are such that the heating system will be required to operate.
3. Switch on the electricity supply to the heater. The fan will start, the 'power on' light on the burner will illuminate and ignition commence.
4. Ignition will occur.
5. If ignition is successful the gas valve will close and the spark ignition de-energize after approximately 10 seconds. For approximately 10 - 20 seconds the fan will purge the system then re-ignition will be attempted. After 3 attempts at ignition the control unit will 'lock-out', the 'power on'

lamp will remain illuminated and the fan will continue to run. To reset after 'lockout', switch off the power supply to the heater and wait 5 minutes. Then turn the power on. If repeated 'lockout' occurs investigate the cause.

8.2. To Switch Off Heater

1. Switch off electrical supply to the heater. The burner will stop and the fan will shut off.

8.3. Servicing

1. To ensure continued efficient and safe operation it is recommended that the heater be serviced regularly by a qualified person every year in normal working conditions but in exceptionally dusty or polluted conditions more frequent servicing may be needed.

Your Local Representative

An AmbiRad Group brand



Ambi-Rad Limited P.O. Box 617
Fishers, Indiana 46038
Telephone 317-577-0337
Facsimile 317-842-3989
Website www.ambirad.com/us

For the Distributor Nearest please call
1-888-330-4878


ENERGY EFFICIENT HEATING SYSTEMS

AmbiRad is a registered trademark of AmbiRad Limited. Because of continuous product innovation, AmbiRad reserves the right to change product specification without due notice.